

NEW

PAGEANT Explained

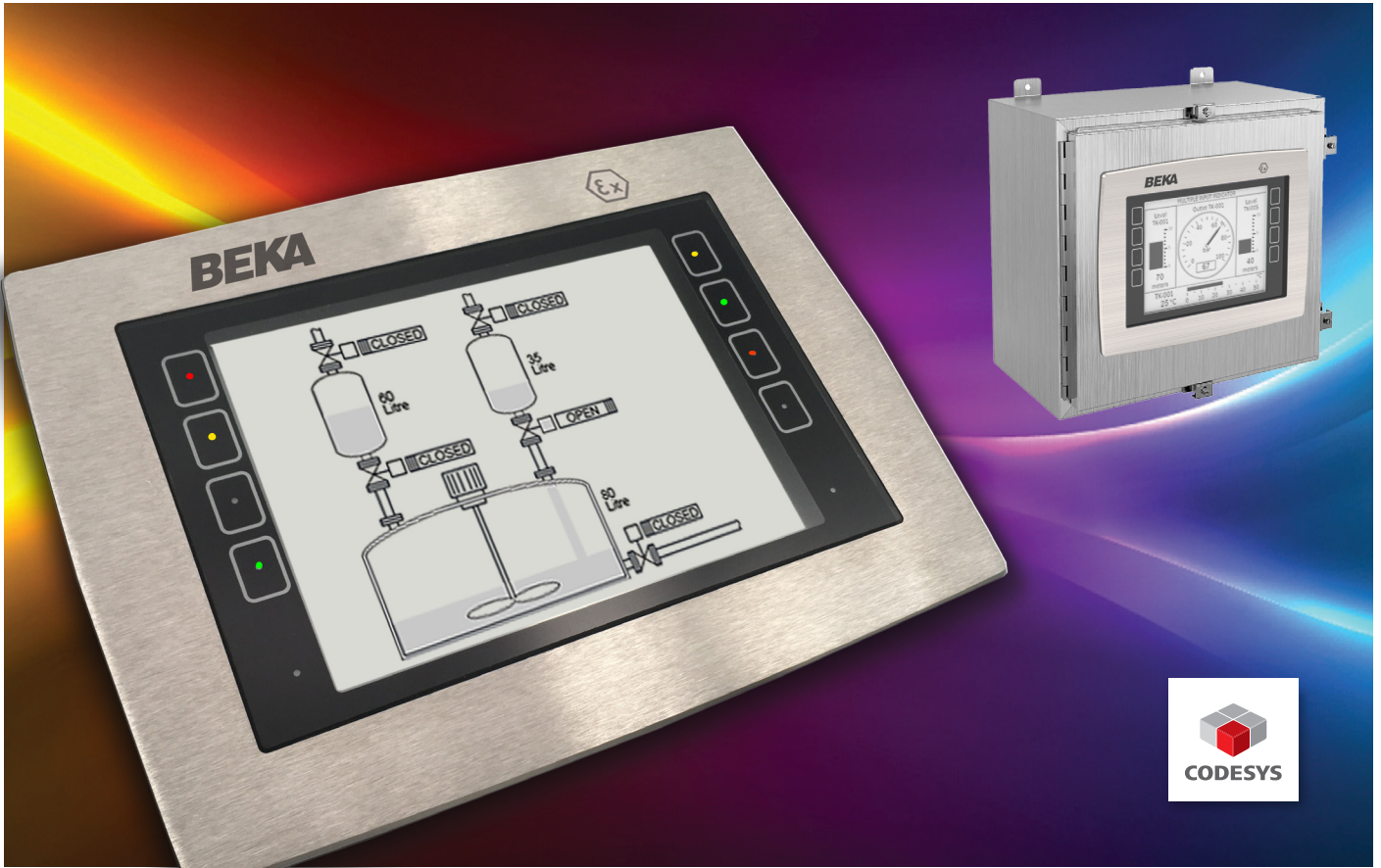

ZONE 1 INTRINSICALLY SAFE OPERATOR PANEL
HMI, PLC, Modular I/O & Comms



- Ex ia intrinsic safety allows installation in Zones 1, 2, 21 or 22
- Two alternative Operator Displays, both with IP66 stainless steel front panels
 - BA3101** Toughened glass window
 - BA3102** Certified impact resistant front panel allows installation in Ex e and Ex t enclosures.
- 7 Inch backlit operator screen
- IEC 61131 compliant PLC
- Up to 7 plug-in input or output modules
- 8 touch buttons with tricolour annunciators
- 3 year guarantee

Pageant Operator Panel System Instructions

CONTENTS

1. **Introduction**
2. **Documentation**
3. **System parts**
 - 3.1 BEKA Power Isolator
 - 3.2 BA3101 & BA3102 Operator Displays
 - 3.3 Plug-in CPU modules
 - 3.4 Plug-in input & output modules
4. **Intrinsic safety certification**
 - 4.1 Gas atmospheres, Zones, gas groups & T rating.
 - 4.2 Dust atmospheres, Zones, types & ignition temperature.
 - 4.3 Special conditions for safe use
 - 4.4 Certification label information
5. **System design**
 - 5.1 Powering a Pageant Operator Panel
 - 5.1.1 Applications in IIA or IIB gas atmospheres.
 - 5.1.2 Applications in IIC gas atmosphere.
 - 5.1.3 Applications in IIIC dust atmosphere.
 - 5.2 Selecting plug-in Input and Output Modules.
6. **Using the Pageant Operator Display**
 - 6.1 Configuration menu
 - 6.2 Diagnostics
7. **Developing CODESYS application PLC code.**
 - 7.1 CODESYS Package
 - 7.2 Transfer of PLC application file to Pageant.
8. **Installation**
 - 8.1 Location
 - 8.1.1 BA3101 Operator Display locations
 - 8.1.2 BA3102 Operator Display locations
 - 8.2 Operator Panel installation procedure.
 - 8.3 Plug-in modules
 - 8.3.1 Plug-in module installation procedure.
9. **Field wiring**
10. **Accessories**
 - 10.1 Tag number
 - 10.2 BA3901 Power Combiner
 - 10.3 BA3902 USB Programming Cable
 - 10.4 BA3903 RS485-IS SUB D Connector
11. **Maintenance**
12. **Guarantee**
13. **Customer comments**
 - Appendix 1 List of plug-in CPU and input & output modules.
 - Appendix 2 RS485-IS port and network.

Issue 4
8th May 2024

The Pageant Operator Displays and all of the plug-in modules are CE marked to show compliance with the *European Explosive Atmospheres Directive 2014/34/EU* and the *European EMC Directive 2014/30/EU*.

The Pageant Operator Displays and all of the plug-in modules are also UKCA marked to show compliance with UK statutory requirements *Equipment and Protective Systems Intended for Use in Potentially Explosive Atmospheres Regulations UKSI 2016:1107 (as amended)* and with the *Electromagnetic Compatibility Regulations UKSI 2016:1091*.

1. INTRODUCTION

Pageant is an intrinsically safe, panel mounting, 7 inch (177mm) backlit Operator Display with touch buttons. It accommodates a plug-in CPU (Central Processing Unit) module containing CODESYS® software, plus a choice of up to seven plug-in input and output modules, all powered by a single BEKA Power Isolator.

The Pageant system is extremely versatile. Applications include remote hazardous area displays with custom screens, and IEC 61131 compliant PLCs with a wide choice of analogue and digital inputs. Operator Displays and plug-in modules have individual intrinsic safety Ex ia apparatus certificates, allowing any combination to be used together without the need for additional third party certification.

For installations in Ex e or Ex t enclosures, Pageant Operator Displays with certified fronts which do not invalidate the enclosure's component certificate are available.

All the software is supplied with a lifetime licence and no renewals or additional payments are required. Optional external communication allows Pageant to be used as part of a network.

The Operator Display and all of the plug-in modules have individual international Ex ia intrinsic safety apparatus certification, this permits any combination of modules to be used without the need for further third party assessment. This flexible certification simplifies system design and minimises cost as only the modules required for each application have to be purchased.

Pageant is totally intrinsically safe providing maximum safety in the most hazardous Zone 0 environments without the need for a heavy expensive enclosure. The Operator Display and all of the plug-in modules are powered from a single BEKA Power Isolator located in a safe area or in Zone 2.

CODESYS runtime PLC software has become an industry standard and is now used in more than 1,500 different products worldwide. It is compliant with international standard IEC 61131 Programmable controllers and will already be familiar to many users.

The Operator Display has eight touch buttons each with a tricolour LED backlight for operator inputs and outputs, all of which are individually programmable. Two additional LEDs indicate status and diagnostics. Operator inputs can also be made via a plug-in DI module from external contacts such as large industrial push buttons.

Two alternative plug-in CPU modules are available. One has an intrinsically safe RS485-IS port which allow the Pageant Operator Panel to be integrated into a network, or to be configured as a Modbus master or slave.

2. DOCUMENTATION

Pageant displays and all plug-in modules are supplied with individual instructions which describe installation and certification. The intrinsic safety certificates for each Pageant device can be downloaded from the BEKA website www.beka.co.uk

This document describes the Pageant concept, how to design, assemble and operate a Pageant PLC system. It should be read in conjunction with the instructions for each module being used.

3. SYSTEM PARTS

There are four parts of the Pageant intrinsically safe Operator Panel system as shown in Fig 1.

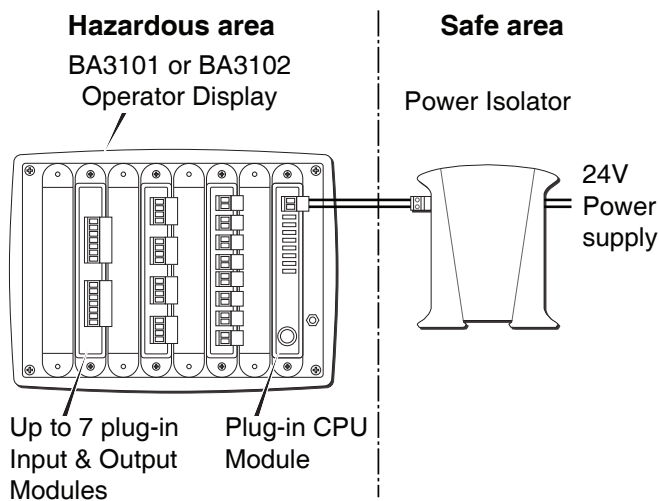

Fig 1 Pageant intrinsically safe Operator Panel system

3.1 BEKA Power Isolator

These galvanic isolators have associated apparatus intrinsic safety Ex ia and increased safety Ex ec component certification. The isolators provide power to the Pageant Operator Panel and may be mounted in a safe area, in Zone 2 or in a dust Zone 22 when provided with additional environmental protection.

Two models are available:

BA212 For powering an Operator Panel located in a IIA or IIB flammable gas, or in a combustible dust atmosphere. May also be used to power an Operator Panel in a IIC flammable gas atmosphere when the BA212 Power Isolator and the Operator Panel are located very close together.

BA243 Four channel supply for powering an Operator Panel located in a IIC flammable gas atmosphere.

3.2 BA3101 and BA3102 Operator Displays

The Operator Displays are IECEx, ATEX and UKEX certified intrinsically safe. They are the core of the Pageant Display Panel comprising a 7 inch (177mm) backlit screen with 8 touch buttons with independent tricolour backlights, plus 8 sockets which can accommodate a single plug-in CPU module and up to 7 plug-in Input and Output Modules. The CPU module also distributes power to the Operator Display and to all of the plug-in I/O modules.

3.3 Plug-in CPU modules

Every Operator Display must be fitted with a plug-in CPU module in the right hand 'C' socket at the rear of the BA3101 Operator Display. All CPU modules contain a microprocessor and memory, together with a removable micro SD card on which is stored the CODESYS runtime software and the PLC application file.

The PLC application code can be updated by removing the micro SD card from the CPU module and transferring it to an SD card writer in the safe area. Alternatively, all CPU modules have a programming port which enables PLC application code to be downloaded to the module in a safe area via a BEKA BA3902 Pageant Programming Cable.

CAUTION

Make a backup copy of the original SD card before any changes are made.

All CPU modules have their own intrinsic safety apparatus Ex ia certification allowing them to be plugged into any BEKA Pageant Operator Display containing any mix of Input and Output modules.

A list of the CPU modules available at the time these instructions were published is contained in Appendix 1. Please see the BEKA website for details of any modules subsequently introduced.

3.4 Plug-in Input and Output Modules

The BA3101 and BA3102 Operator Displays can accommodate up to seven plug-in Input and Output interface modules (I/O modules) in the sockets at the rear of the Display. These enable analogue and digital sensors and signals such as switch contacts, proximity detectors and 4/20mA process signals to be input to, and output from the Pageant system.

Each module has its own intrinsic safety Ex ia apparatus certification and includes removable terminals for connecting field wiring.

A list of the interface I/O modules available at the time these instructions were published is contained in Appendix 1. Please see the BEKA website for details of any modules subsequently introduced.

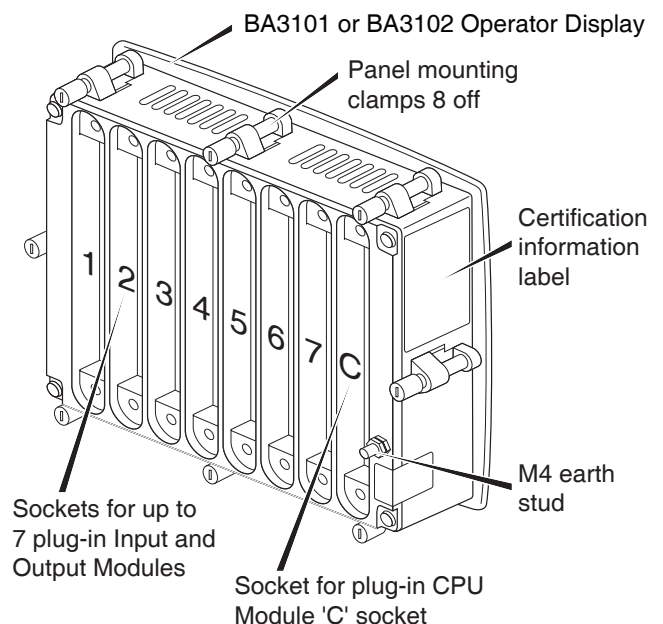

Fig 2 Rear of BA3101 display without plug-in modules

4. INTRINSIC SAFETY CERTIFICATION

EU Notified Body CML B.V. and UK Approved Body Eurofins CML have issued the Pageant Operator Display and each of the plug-in modules with individual IECEx, ATEX and UKEX Ex ia intrinsic safety apparatus certificates. The certificates for the BA3101 and BA3102 displays and each module are described in the instructions which accompany each item and can also be downloaded from www.beka.co.uk

The ATEX certificates have been used to confirm compliance with the European ATEX Directive for Group II, Category 1G and 1D equipment, similarly the UKEX certificates have been used to confirm compliance with the UK Statutory Instrument UKSI 2016:1107 (as amended).

The Operator Displays and all the plug-in modules carry both the CE and UKCA marks. Subject to local codes of practice, they may all be installed in any of the European Economic Area (EEA) member countries and in the UK. ATEX certificates are also acceptable for installations in some non EEA countries. The IECEx certification is acceptable worldwide, either directly or as an aid to obtaining local approval.

The Operator Displays have no external connections apart from the seven sockets for the plug-in interface modules and the single 'C' socket for a plug-in CPU module. The intrinsic safety input and output safety parameters of the Operator Display sockets and all of the plug-in modules have been designed to allow any certified BEKA interface module to be safely plugged into any of the seven Operator Display sockets. Similarly, any certified BEKA CPU module may be safely plugged into the 'C' socket on the Operator Display. Each module certificate specifies that the module should only be used as part of a BEKA Pageant System.

When each plug-in module was assessed for intrinsic safety certification by a Notified and/or Approved Body, it was considered as being connected to (plugged into) a certified Pageant Operator Display. To maximise flexibility the BA3101 and BA3102 certificates do not list all the modules that may be fitted, but for compliance with EN 60079-25 *Intrinsically safe electrical systems*, the Operator Display and modules may be considered a certified intrinsically safe system only requiring a simplified Descriptive System Document.

These instructions describe IECEx, ATEX and UKEX installations which conform with IEC / EN 60079-14 *Electrical installations design, selection and erection*. When designing systems the local code of practice should be consulted.

4.1 Gas atmospheres - Zones, gas groups and T rating

Certificates for the Operator Displays and all of the plug-in modules specify the same gas code:

$$\text{Ex ia IIC T4 Ga } -40^{\circ}\text{C} \leq \text{Ta} \leq 65^{\circ}\text{C}$$

When fitted with a certified BEKA plug-in CPU module and certified BEKA plug-in Input and Output Modules, the Operator Displays may be installed in:

Zone 0	Explosive gas air mixture continuously present. Unlikely requirement
Zone 1	Explosive gas air mixture likely to occur in normal operation.
Zone 2	Explosive gas air mixture not likely to occur, and if it does will only exist for a short time.

Be used with gases in groups:

- Group A Propane
- Group B Ethylene
- Group C Hydrogen

In gases that may be used with equipment having a temperature classification of:

T1	450°C
T2	300°C
T3	200°C
T4	135°C

At an ambient temperature T_a between -40°C and $+65^{\circ}\text{C}$.

4.2 Dust atmospheres

Zones, types & ignition temperature

Certificates for the Operator Displays and all of the plug-in modules specify the same dust code, but have different maximum surface temperatures:

Exia IIIC T x°C Da $-40^{\circ}\text{C} \leq \text{Ta} \leq 65^{\circ}\text{C}$.

For applications in dust atmospheres, the certificates specify Special Conditions of Use (See section 4.3) which require the rear of the Operator Panel to have additional environmental protection. This requirement can be satisfied by mounting the Operator Displays and the plug-in modules, in a component certified Ex t enclosure with certified Ex t cable glands.

When fitted with a BEKA certified plug-in CPU and input & output modules, and mounted inside an Ex t enclosure with Ex t cable glands, Pageant Operator Displays may be installed in:

Zone 20	explosive atmosphere in the form of a cloud of combustible dust in air is continuously present, for long periods or frequently.
Zone 21	explosive atmosphere in the form of a cloud of combustible dust in air is likely to occur occasionally in normal operation.
Zone 22	explosive atmosphere in the form of a cloud of combustible dust in air is not likely to occur in normal operation, but if it does occur, will only persist for a short period.

Be used with dust in subdivisions:

IIIA	combustible flyings
IIIB	non-conductive dust
IIIC	conductive dust

The apparatus certificates for the Operator Displays specifies that when installed in an enclosure the maximum surface temperature assigned to the Operator Display, which is 135°C, shall take precedence to the surface temperature assigned to any plug-in module which may be installed in the Operator Display.

When mounted in an enclosure the Operator Displays may therefore be used with dusts having a Minimum Ignition Temperature of:

Dust cloud	202°C
Dust layer on enclosure up to 5mm thick	210°C
Dust layer on enclosure over 5mm thick.	Refer to EN 60079-14

At an ambient temperature between -40 and +65°C

4.3 Special conditions for safe use

The IECEx, ATEX and UKEX certificate numbers for the BA3101 and BA3102 Operator Displays and all of the plug-in modules have an 'X' suffix indicating that special conditions for safe use apply. Overall they are as follows, but please refer to certificates for details.

- Under certain extreme circumstances, the non-metallic parts incorporated in the enclosure of this equipment may generate an ignition-capable level of electrostatic charge. Therefore, the equipment shall not be installed in a location where the external conditions are conducive to the build-up of electrostatic charge on such surfaces. In addition, the equipment shall only be cleaned with a damp cloth.
- The metal bezel of the equipment shall be connected to earth via the integral earth stud.
- In installations requiring EPLs Da, Db, or Dc, the surface temperature assigned to this equipment shall take precedence over the surface temperature assigned to any plug-in module which may be installed within its enclosure.
- In installations requiring EPL Da, Db, or Dc, the equipment shall be mounted to an enclosure which provides a minimum degree of protection of IP5X and which meets the requirements of EN60079-0 Clause 8.4 (material composition requirements for metallic enclosures for Group III) and/or EN60079-0 Clause 7.4.3 (Avoidance of a build up of electrostatic charge for Group III) as appropriate.

All cable entries into the equipment enclosure shall be made via cable glands which provide a minimum degree of protection of IP5X.

4.4 Certification label information

The Operator Display and all of the plug-in modules are fitted with separate certification information labels. Each shows the model number, certification information and BEKA associates address and year of manufacture together with a serial number.

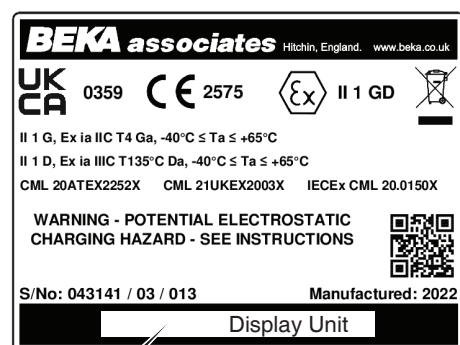

BA3101
BA3102

Typical certification information label

5. SYSTEM DESIGN

Fig 1 illustrates a basic Pageant Operator Panel System. Design of the system can be divided into a series of steps as follows.

5.1 Powering a Pageant Operator Panel

Pageant Operator Panels are powered by a BEKA Power Isolator located in a safe area or in Zone 2. Which isolator model is required depends upon the hazardous area gas group in which the Pageant Operator Panel is installed. Detailed Power Isolator installation instructions are supplied with each isolator and can be downloaded from www.beka.co.uk. Additional detailed information is contained in BEKA Power Isolator Application Guide AG210 which can also be downloaded from www.beka.co.uk.

5.1.1 Applications in IIA or IIB gas atmospheres

A BEKA BA212 Power Isolator should be used to power a Pageant Operator Panel installed in a hazardous area containing gases in groups IIA or IIB as shown in Fig 3.

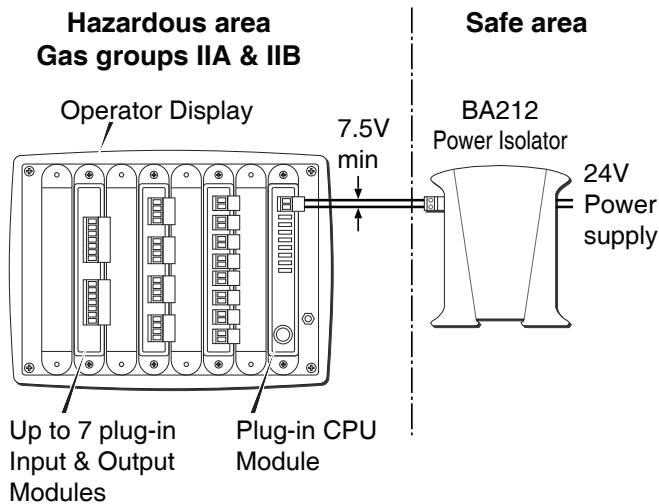

Fig 3 Application in gas group IIA or IIB

The plug-in CPU module distributes power to the BA3101 display and all of the plug-in interface modules from the BA212 Power Isolator. The equivalent internal capacitance C_i and inductance L_i at the power supply terminals of all plug-in CPU modules are zero. Therefore the maximum permitted intrinsic safety parameters of the cable between the BA212 Power Isolator and the CPU module C_c , L_c and L_c/R_c are defined by, and are the same as, the output safety parameters of the isolator.

The C_o of the BA212 Power Isolator is $1.24\mu\text{F}$ in a IIC atmosphere, this is relatively large and unlikely to impose any practical cable length restrictions.

The inductive safety parameters of the cable between the BA212 Power Isolator output and the CPU plug-in module in the Operator Panel should comply with one of the following two alternatives:

Gas group	IIA	IIB
Lc inductance	$\leq 40\mu\text{H}$	$\leq 20\mu\text{H}$
OR		
Lc/Rc ratio	$\leq 34\mu\text{H}/\Omega$	$\leq 17\mu\text{H}/\Omega$

To comply with the total cable inductance requirement, the cable manufacturers specification should be consulted to determine the cables inductance per metre. Most twisted pair instrument cables have an inductance of less than $0.8\mu\text{H}/\text{m}$. Depending upon the cable selected, lengths slightly longer than the following are achievable:

Gas group	IIB	IIA
Max cable length	25m	61m

Alternatively, complying with the L_c/R_c ratio requirement will allow a longer cable, limited by the cable's resistive voltage drop, to be used.

Instrumentation cables complying with the L_c/R_c ratio required for use in IIB gases are produced by a number of manufacturers. For example, the Draka Norsk Kabe FlexFlame RFOU(i) 150/250(300) cable has 0.75mm^2 conductors and is available with single and multi twisted pairs with and without screens and armour. Each single twisted pair has the following electrical parameters:

Inductance	Resistance	L/R ratio
$0.67\mu\text{H}/\text{m}$	$26.3\text{m}\Omega/\text{m}$	$12.7\mu\text{H}/\Omega$

The minimum operating voltage at the plug-in CPU power supply terminals in the hazardous area is 7.5V. The current consumption of the Operator Panel depends upon the number and type of plug-in I/O modules fitted as shown below:

Module total % power consumption	Operator Panel maximum current consumption
20%	300mA
100%	400mA

See section 5.2 and Appendix 1 for plug-in module loading information.

Using the recommended cable the maximum permitted cable lengths are:

Gas group IIB and IIA	20% total module power consumption	100% total module power consumption
Max cable length	137m	73m

Significantly longer cables can be used for IIA applications if a cable with a lower dc resistance having an L/R ratio of less than $34\mu\text{H}/\Omega$ is used.

Additional detailed information about maximum permitted cable lengths is contained in the BEKA Power Isolator Application Guide AG210 which can be downloaded from www.beka.co.uk.

5.1.2 Applications in a IIC gas atmosphere

The BA212 Power Isolator is not suitable for most applications in group IIC gases. The maximum permitted external inductance L_o for a BA212 in a IIC hydrogen atmosphere is $5\mu\text{H}$ which only allows a cable length of a few metres. The isolator's IIC L_o/R_o ratio is $4.3\mu\text{H}/\Omega$, for which compliant cables are not generally available.

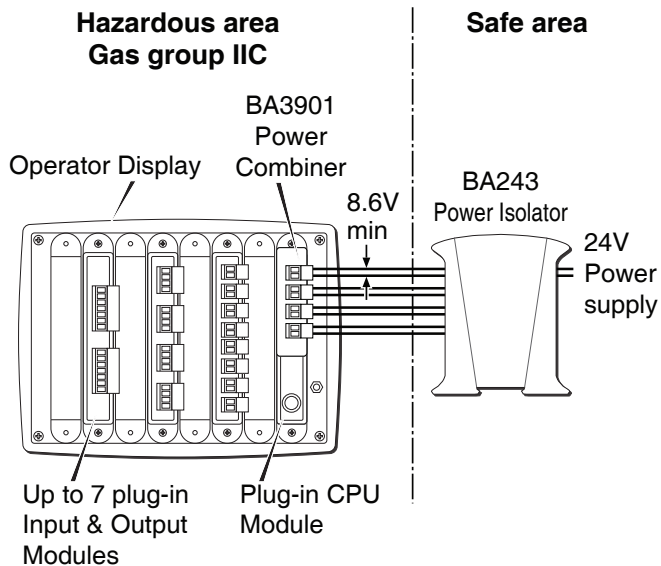

Fig 4 Application in gas group IIC

The BA243 Power Isolator has four separately galvanically isolated outputs which are spark ignition safe in a IIC atmosphere when they are all connected in parallel. However, the large combined output current of the four parallel channels would reduce the inductance L_o that may be safely connected and hence the length of the cable between the Power isolator and the Pageant Operator Panel. This limitation can be overcome by treating each channel as a separate intrinsically safe circuit and remotely combining them at the Pageant Operator Panel as shown in Fig 4.

The BA3901 certified Power Combiner (4 Way Power Terminal Accessory) ensures that the four supplies remain isolated even under fault conditions. It mounts onto the rear of any plug-in CPU module and includes terminals for the four separate supplies. See section 10.2.

The C_o of each BA243 Power Isolator output is $1.24\mu\text{F}$ in a IIC atmosphere, this is relatively large and is unlikely to impose any practical cable length restrictions.

The inductive safety parameters of each cable connecting the BA243 Power Isolator to the BA3901 Power Combiner at the Operator Panel should comply with one of the following two alternative safety parameters:

Gas group	IIC
L_c inductance	$\leq 79\mu\text{H}$
OR	
L_c/R_c ratio	$\leq 17\mu\text{H}/\Omega$

To comply with the total cable inductance requirement, the cable manufacturers specification should be consulted to determine the cables inductance per metre.

Most twisted pair instrument cables have an inductance of less than $0.8\mu\text{H}/\text{m}$. Using the Draka Norsk Kabe FlexFlame RFOU(i) 150/250(300) cable recommended in the previous section 5.1.1, in a IIC atmosphere allows lengths of up to:

$$\text{Max cable length in IIC} = 79\mu\text{H}/0.67\mu\text{H}/\text{m} = 117\text{m}$$

Alternatively, complying with the L_c/R_c ratio requirement will allow a longer cable, limited by the cable's resistive voltage drop, to be used.

The minimum operating voltage at the BA3901 Power Combiner terminals in the hazardous area is 8.6V. The current consumption of the Pageant Operator Panel depends upon the number and type of plug-in I/O modules fitted as shown below:

Module total % power consumption	Operator Panel maximum current consumption
20%	300mA
100%	400mA

See section 5.2 and Appendix 1 for loading information.

Using the recommended Draka Norsk Kabe FlexFlame RFOU(i) 150/250(300) cable the maximum permitted cable lengths are:

	Total % module power consumption	
	20%	100%
Max cable length in IIC	365m	177m

If the four outputs of the BA243 Power Isolator are connected to the remote BA3901 Power Combiner via a multicore cable, to maintain isolation between the four supplies the cable should be a Type A or a Type B multicore as defined in IEC 60079-14.

More detailed information about maximum permitted cable lengths is contained in BEKA Application Guide AG210 Power Isolators.

5.1.3 Applications in a IIIC dust atmosphere

For applications in a combustible dust atmosphere the Pageant Operator Panel should be powered in exactly the same way as for use in gas groups IIA and IIB described in section 5.1.1

The Operator Panel should be mounted in an enclosure providing IP5X protection for the rear of the Operator Panel. A metallic enclosure should comply with the requirements of EN60079-0 Clause 8.4 and/or EN60079-0 Clause 7.4.3 for a plastic enclosure.

All cable entries into the equipment enclosure should be made via cable glands which provide a minimum degree of protection of IP5X.

These requirements are satisfied by mounting the Operator Panel in an Ex t component certified enclosure fitted with Ex t cable glands.

5.2 Selecting plug-in Input and Output Modules

Operator Displays can accommodate up to seven plug-in Input and Output Modules which should be selected to satisfy the applications input and output requirements. The intrinsic safety certification of all the modules and the Operator Displays permit any combination of modules to be fitted, but there are power limitations.

The datasheet and instructions for each plug-in Input and Output Module specify the percentage of the total available power from a Operator Display that the module consumes. Consumptions are also shown in Appendix 1 of this document. The sum of the percentage power consumptions of all the plug-in modules must not exceed 100%.

Example of 6 module combination:

Qty.	Model	Function	% of available power module consumes
2	BA3701	Totaliser / Counter Module	2 x 24% = 48
1	BA3402	Digital NAMUR Input Module	1 x 40% = 40
3	BA3301	Analogue Input Module	3 x 4% = 12
Total power consumption			100%
<i>(Total equals 100% therefore acceptable)</i>			

Example of 7 module combination:

Qty.	Model	Function	% of available power module consumes
5	BA3401	Digital Input Module	5 x 4% = 20
2	BA3601	Digital Output Module	2 x 4% = 8
Total power consumption			28%
<i>(Total less than 100% therefore acceptable)</i>			

Example of 6 module combination:

Qty.	Model	Function	% of available power module consumes
2	BA3701	Totaliser / Counter Module	2 x 24% = 48
2	BA3402	Digital NAMUR Input Module	2 x 40% = 80
3	BA3301	Analogue Input Module	3 x 4% = 12
Total power consumption			140%
<i>(Total exceeds 100% therefore unacceptable)</i>			

6. USING THE PAGEANT OPERATOR DISPLAY

When power is applied to a BEKA Operator Display from a Power Isolator the panel will immediately start to boot up from the SD-card in the CPU module. After a short delay the start-up sequence provides access to the configuration menu for approximately ten seconds before automatically loading the CODESYS runtime software and starting the PLC application code.

The configuration menu enables the operating conditions of the Pageant panel, such as display brilliance and access code to be adjusted and defined. If the configuration menu is not accessed during the start-up sequence the PLC application code will automatically start.

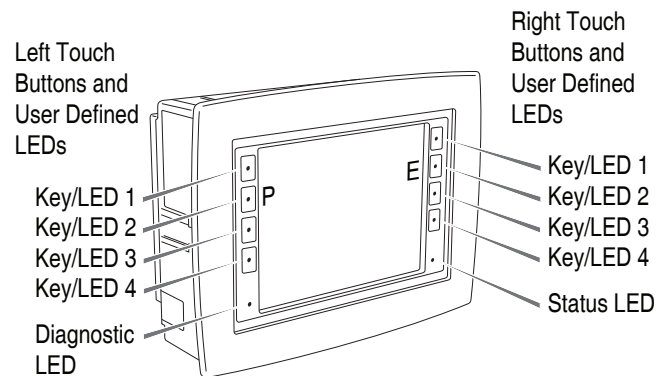

Fig 5 Controls and annunciators

The start-up sequence is as follows:

Approximate elapsed time after power applied	Action	Status LED
0	Blank screen	Red
35s	BEKA logo on screen	Red
45s	P and E buttons identified by amber backlights, operating both simultaneously accesses the configuration menu.	Flashing red*
55s	P and E buttons backlight extinguished, configuration menu can no longer be accessed.	Red
65s	User PLC programme is loading or is in a stopped state.	Amber
	User PLC programme is running.	Green

* If the LED indicators, including the status LED, have been totally dimmed, the configuration menu can be accessed by simultaneously pressing the **P** and **E** buttons immediately after the BEKA logo is displayed.

While the status lamp is flashing red the configuration menu can be accessed by simultaneously operating the touch buttons identified by amber backlights which are the **P** (Left hand key 2) and **E** (Right hand key 2) buttons. The configuration menu is protected by a four digit alphanumeric security code, if the security code is set to the default '0000' the first screen 'Menu' will be displayed. If a security code other than the default code '0000' has already been entered, 'Access Code Entry' will be displayed which is a request for the access code to be entered.

6.1 Configuration menu

The configuration menu structure is shown in Fig 8. Touch buttons which are active for each selected sub-menu have a green backlight and their function is shown on the screen adjacent to the button.

Button functions are:

- P & E** Enter configuration menu
- P** Enter into a sub-menu or trigger an action
- E** Exit from a sub-menu, save settings or answer a question.
- ▲** Move the cursor up the screen
- ▼** Move the cursor down the screen
- ▶** Move the cursor to the right
- ◀** Move the cursor to the left

All menu functions will time-out if the delay between operating an active touch button exceeds sixty seconds. After time-out has occurred the Pageant panel will automatically continue the start-up sequence.

6.2 Diagnostic

The diagnostic LED on the Pageant front panel provides basic information about system health. When not illuminated the system is operating correctly.

Diagnostic LED	Fault	Corrective action required
Flashing red	Corrupt memory	Return Operator Display to BEKA logo
Red	Plug-in module failed in CODESYS application	Ensure that the correct Device Description file(s) has been used in the CODESYS IDE
Flashing amber	Device description error	Ensure that the correct Device Description file(s) has been used in the CODESYS IDE
Amber	Operator Display over temperature	Determine cause of Operator Display overheating
Flashing green	Incorrect plug-in module	Ensure that the plug-in I/O module slots specified in the CODESYS IDE match where the plug-in I/O modules have been fitted

7. Developing CODESYS application PLC code

PLC application code for Pageant should be developed within a CODESYS Integrated Development Environment (IDE). This may be downloaded free of charge from the CODESYS website to a PC having a Windows 8.1, 10 or 11, 64 bit operating system. Recommended minimum system requirements are:

- 2.5 GHz Processor
- 8 GB RAM
- 12 GB available HD space

No software licence is required to download and use this IDE which complies with IEC 61131 and will be familiar to many users.

7.1 CODESYS Package

Before starting a project in the CODESYS IDE, the latest CODESYS Control for Pageant package should be installed via the Package Manager. This file is available for free from the BEKA website at https://www.beka.co.uk/pageant_codesys_files.html.

The package contains:

- The Device Description Files for the Pageant CPU Module, Pageant Display and plug-in I/O modules.
- A BEKA project template with the devices and visualization inserted in the Project device tree.
- A Visualization style which will constrain the colour palette in the visualization elements to grey scale.

7.2 Transferring a PLC application file to Pageant

After a new or modified PLC application file has been developed within a CODESYS Integrated Development Environment (IDE) it can be transferred to the Pageant Operator Display in a number of ways.

CAUTION

Make a backup copy of the original SD card before any changes are made.

- The easiest and fastest technique is to unplug the CPU module from the Hazardous area Pageant Operator Display and remove the micro SD card as shown in Fig 6.

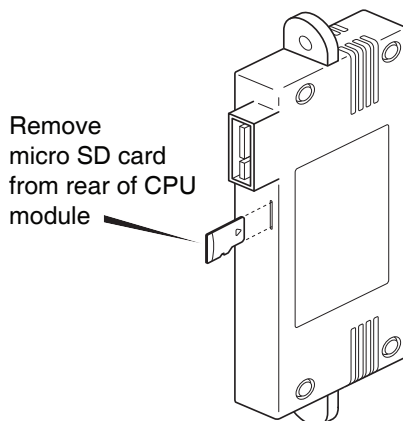

Fig 6 Removing micro SD card from plug-in CPU module

Using an SD card writer the revised compiled PLC application code can be copied to the micro SD card in a safe area. A Windows based system will show 4 removable drives on the Pageant SD card:

- Kernel
- Unknown Format
- Unknown Format
- BEKA

|----Logs

Contains files that may assist BEKA in the event of a problem.

|----Runtime Update

For storing a CODESYS Runtime program update which may be accepted using the Runtime update screen in the configuration menu.

|----User Data

For user PLC application data

|----User Program Update

For compiled user PLC program application file which may be accepted using the User Program Update screen in the configuration menu.

The CODESYS generated boot application files and subfolders should be copied to the User Program Update area in the BEKA drive.

The card should then be replaced in the CPU module which should be reinstalled in the Pageant Operator Display.

Once the product has booted up, go in the BEKA Configuration Menu and update the application via the User Program Menu.

Exiting the Configuration Menu will cause the revised PLC application to automatically start.

- Alternatively, but not so fast as method 'a'. If a duplicate Pageant Operator Display is available in a safe area, the hazardous area Operator Panel CPU module should be transferred to the safe area Pageant Operator Display.

Using a BA3902 Programming Cable to connect a USB port on the PC hosting the CODESYS IDE to the programming port on the CPU module, the compiled updated PLC application file can be copied to the CPU module. Finally, the CPU module should be transferred back in the hazardous area Pageant Operator Panel.

The BA3902 Programming Cable shown in Fig 7 ensures that the intrinsic safety components within the CPU module are not damaged if a fault develops in the PC.

When installing or removing a plug-in CPU module in a Pageant Operator Display, the CPU module should not be powered.

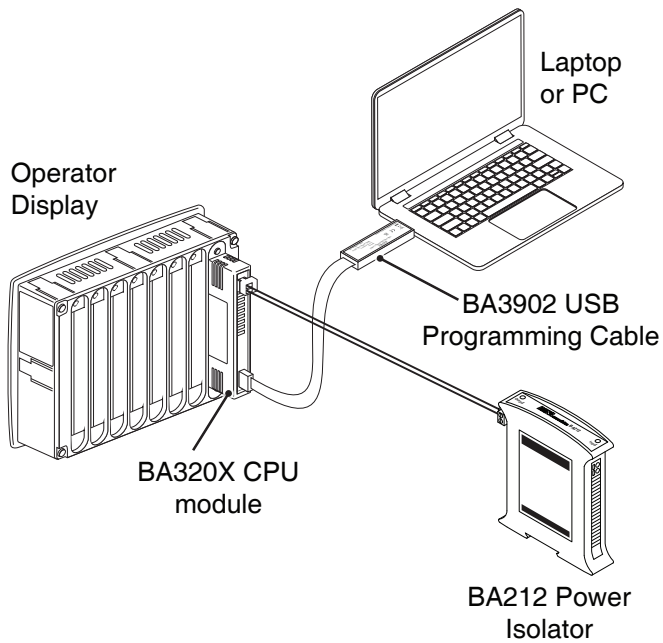

Fig 7 Transferring PLC application file to Pageant in a safe area

- c. If a gas clearance certificate is available for the hazardous area in which the Pageant Operator Panel is installed, method 'b' can be used to transfer the compiled PLC user application file directly to the CPU module in the hazardous area. When the status LED flashes red during the Pageant start-up sequence, the (and) buttons should be operated simultaneously to access the configuration menu. The menu enables the new user program to be accepted using the 'User Program Update' screen.

CAUTIONS

Unless a gas clearance certificate is available, BA3200 series CPU modules should only be reprogrammed in a safe area.

A BEKA BA3902 CPU Module Programming Lead should be used to connect the programming port to the programming computer.

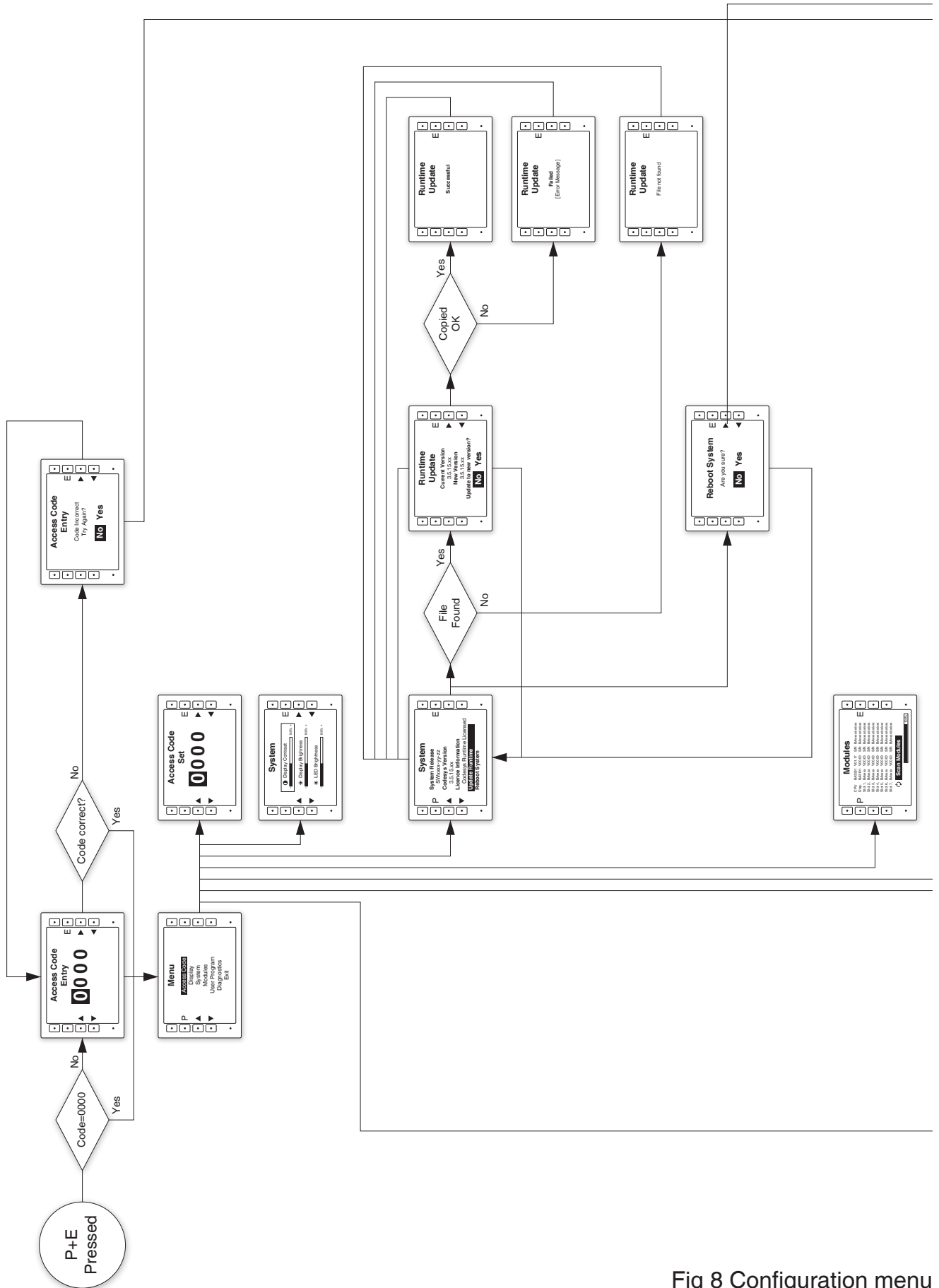
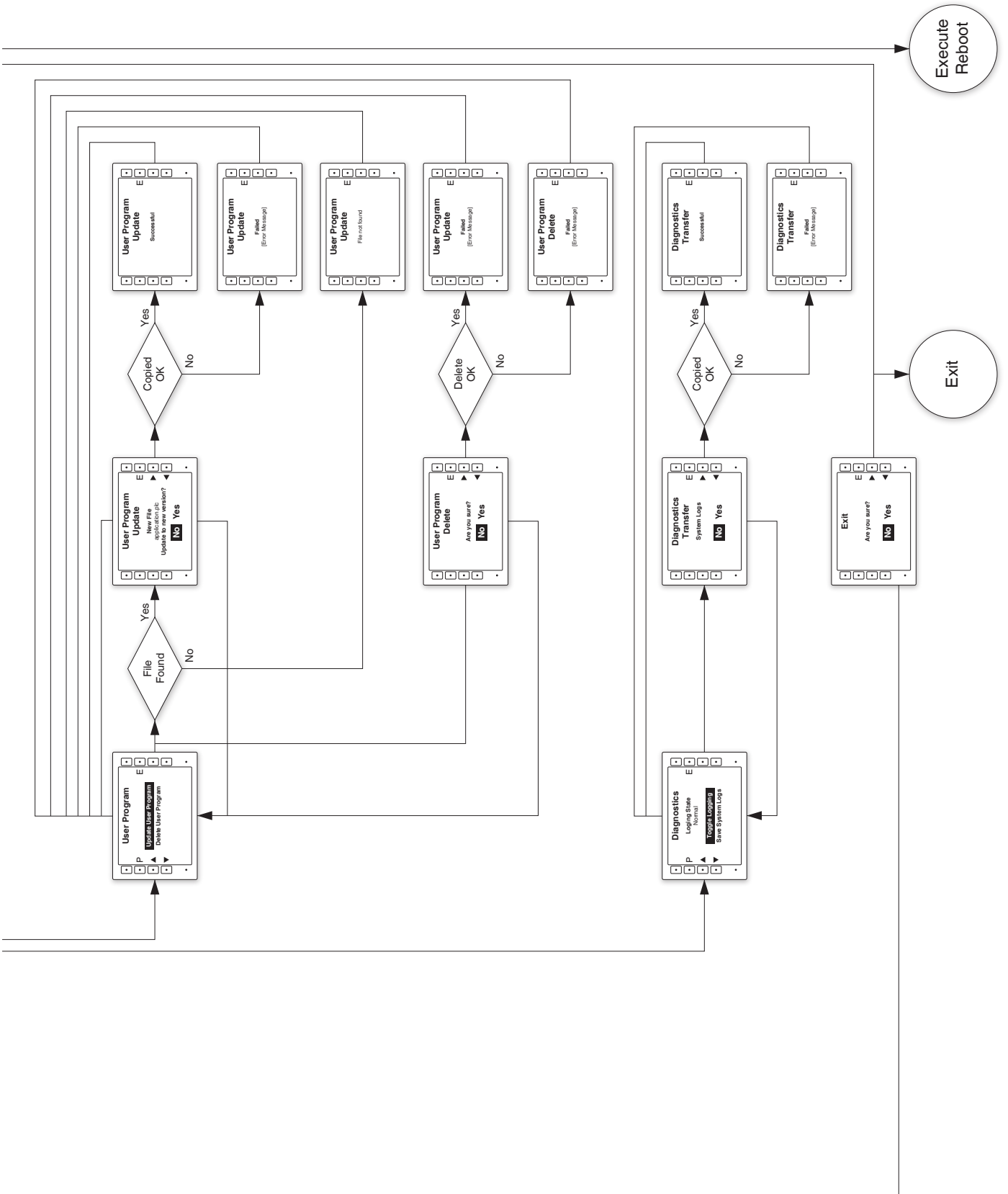

Fig 8 Configuration menu



8. INSTALLATION

8.1 Locations

When designing or installing a Pageant system for use in a hazardous area, the BA3101 and BA3102 Operator Display Installation Instructions which are supplied with every instrument, and the appropriate intrinsic safety certificates should be consulted. All Pageant documentation can be downloaded from the BEKA website www.beka.co.uk

8.1.1 BA3101 Operator Display location

The BA3101 Pageant Operator Display has a 316 stainless steel front panel surrounding the backlit display which is protected by a 4mm thick toughened glass window. The front of the Operator Display has certified IP66 ingress protection.

The rear of the BA3101 has IP20 protection.

8.1.2 BA3102 Operator Display location

The BA3102 Pageant Operator Display has a 316 stainless steel front panel surrounding the backlit display which is protected by a scratch resistant 4mm thick polycarbonate window. The front of the Operator Display has certified impact and IP66 ingress protection which allows the BA3102 to be installed in a certified Ex e or Ex t enclosure without invalidating the enclosure's component certification.

The rear of the BA3102 has IP20 protection.

CAUTION

The front panel touch buttons can be operated with a gloved finger, but if they are likely to be exposed to salt water, it is recommended that operator inputs in the CODESYS PLC application be made using external sealed mechanical switch contacts via a BA3401 digital input module.

Fig 9 shows the overall dimensions including the plug-in modules and the recommended panel cut-out dimensions.

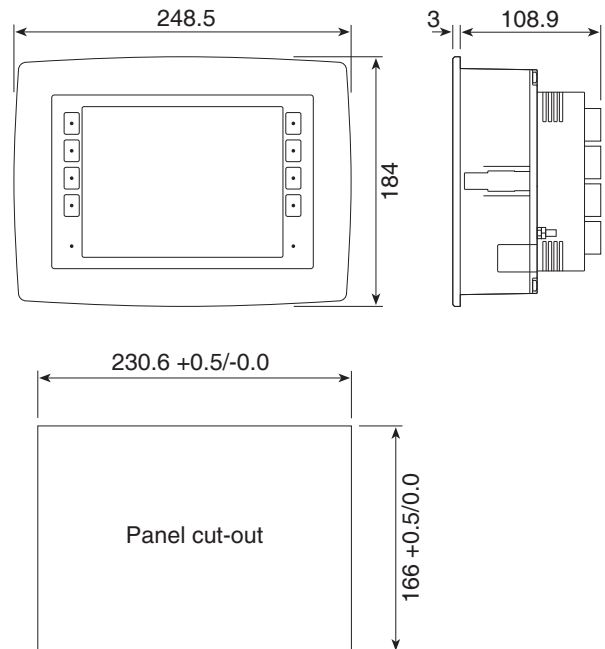

Fig 9 Pageant Operator Display dimensions including plug-in modules and panel cut-out.

8.2 Operator Panel Installation Procedure

1. Cut the aperture specified in Fig 9 in the instrument panel or enclosure and ensure that all edges are de-burred.
2. First ensure that all eight panel mounting clamps are closed by turning the knurled screws fully anticlockwise until the two pips in the clamp foot align with holes in the clamp body as shown in Fig 10.
3. Ensure that the panel sealing gasket is correctly positioned before inserting the Operator Panel into the aperture.
4. Place a clamp in the recess on each side of the Operator Panel, pulling gently to slide it onto the dovetail as shown in Fig 10. Push the knurled screw slightly forward to engage the thread and tighten by turning clockwise until it is just finger tight. When both clamps are fitted ensure that the gasket behind the front panel bezel remains correctly positioned before fitting the remaining panel mounting clamps. Finally, fully tighten all 8 panel clamps to secure the instrument. The maximum recommended clamp tightening torque is 25cNm (2.2 lbf in) which is approximately equivalent to finger-tight plus one half turn. Do not over tighten.

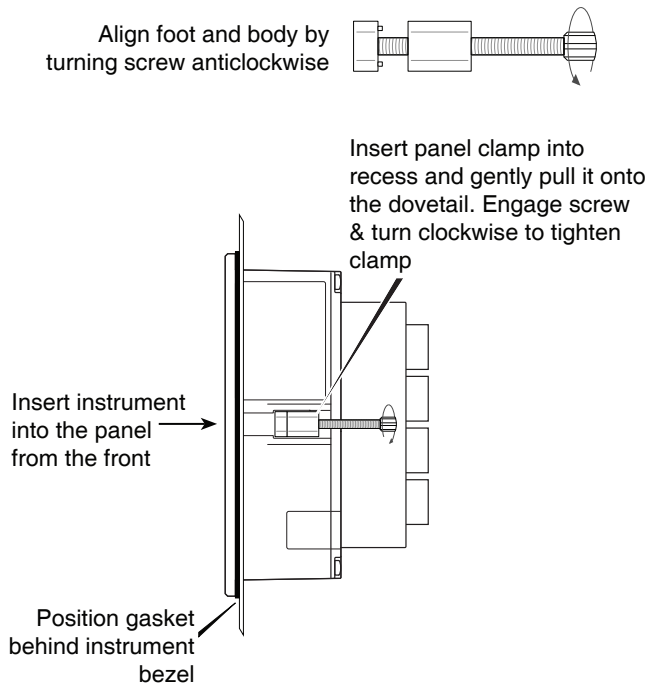

Fig 10 Installation of panel mounting clamps

8.3. Plug-in modules

Operator Displays can accommodate one plug-in CPU module in the right hand socket, marked 'C' and up to seven plug-in input or output modules in the remaining sockets marked 1 to 7 as shown in Fig 2. Modules have keyed plugs to ensure that CPU and Input and Output Modules can not be interchanged.

All Operator Displays must be fitted with a CPU module, but the number of plug-in Input and Output Modules that may be fitted depends upon the application and may vary between zero and seven. Input and Output Modules may be fitted in any of the seven sockets most convenient for field wiring. Their location is defined in the PLC programme when the application is designed in the CODESYS IDE prior to being transferred to the CPU module.

8.3.1 Plug-in module installation procedure

All Pageant plug-in modules are installed in the same way and may be fitted before or after the Operator Display is installed in the instrument panel. Ensure that the Operator Display is not powered while a plug-in module is being added or removed.

For an installation in a hazardous area, all the plug-in modules must be manufactured by BEKA and have certification that specifies that the module should be used as part of a BEKA Pageant System.

Each module should be inserted into the selected socket and secured by tightening the two module captive screws, as shown in Fig 11.

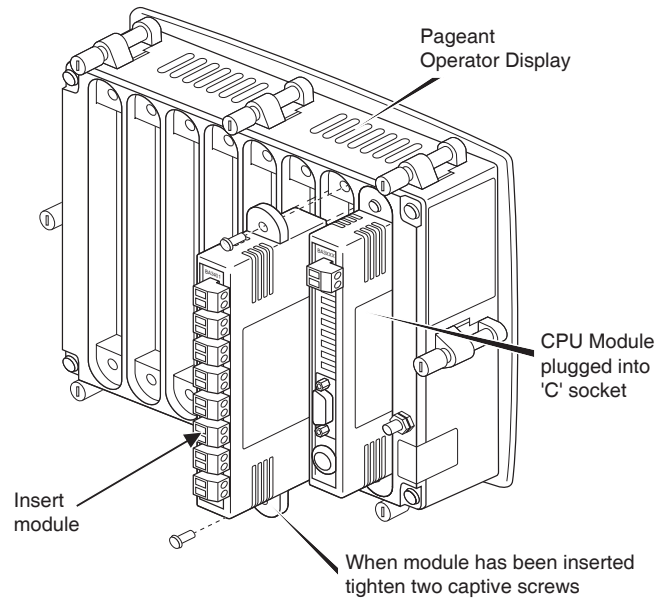

Fig 11 Installing plug-in modules

9. FIELD WIRING

All field connections to the Operator Display are made via the terminals on the plug-in modules which are described in the instructions supplied with each module. Apart from the earth stud, there are no direct field connections to the Pageant Operator Displays.

The M4 earth stud is located on the right hand side at the rear of the Operator Panel as shown in Fig 2. It should be connected to the metallic structure of the panel or enclosure in which the Pageant Operator Panel is mounted which should also be earthed.

To simplify installation all module field wiring terminals are removable by gently pulling. Wiring should be supported to prevent damage to the connectors, particularly in installations subject to vibration.

10. ACCESSORIES

10.1 Tag number

The Pageant Operator Panel can be supplied with a customer defined tag number and application information thermally printed on a self adhesive label fitted to the side of the panel.

10.2 BA3901 Power Combiner (4 Way Power Terminal Accessory)

The BA3901 is a certified 4 Way Power Terminal Accessory which remotely combines the output of four separate intrinsically safe power supplies. When used with a BEKA BA243 Power Isolator, it allows longer cables to be used between the isolator and the Operator Panel installed in a IIC hazardous gas atmosphere.

The 4 way Power Combiner may be fitted to any certified Pageant BA3200 series CPU module as shown in Fig 12. It includes four pairs of removable screw connectors for terminating field wiring.

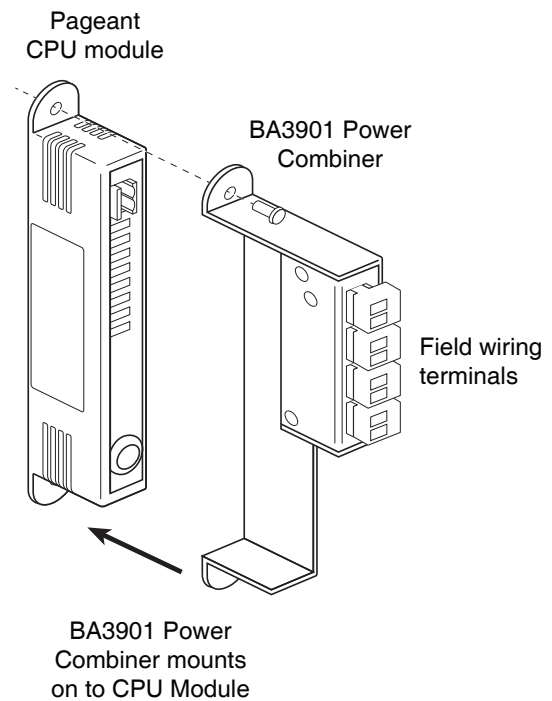

Fig 12 BA3901 Power Combiner mounts onto a CPU module

10.3 BA3902 USB programming cable

The BA3902 cable connects the programming port on a plug-in CPU module to a USB port on a personal computer, enabling CODESYS application code to be downloaded to the CPU module. The cable incorporates isolation and power limitation to prevent the CPU module's intrinsic safety components being damaged if the personal computer develops a fault. The CPU module requires powering during downloading which may only be performed in a non hazardous safe area, or when a gas clearance certificate is available.

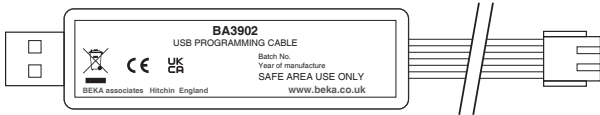

Fig 13 BA3902 USB programming cable

10.4 BA3903 RS485-IS SUB D 9 Connector

RS485-IS is a 2-wire intrinsically safe communications standard where field wiring can be looped through up to 32 devices on a single segment. The BA3903 mates with the standard female connector on an RS485-IS device, such as a Pageant plug-in CPU module. The connector contains duplicate input and output screw terminals enabling twisted pair field wiring to be easily connected. It also contains a switchable terminating resistor for use at the end of the RS485-IS line.

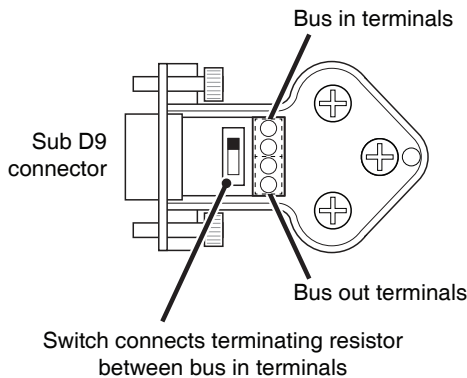

Fig 14 BA3903 RS485-IS SUB D 9 Connector

11. MAINTENANCE

The Pageant Operator Panel and plug-in modules should be regularly inspected to ensure that they have not been damaged. The frequency of inspection depends upon environmental conditions.

No attempt should be made to repair a faulty Pageant Operator Display or plug-in module. Suspect Operator Displays or modules should be returned to BEKA associates or your local BEKA agent.

12. GUARANTEE

Operator Displays and plug-in modules which fail within the guarantee period should be returned to BEKA associates or your local BEKA agent. It is helpful if a brief description of the fault symptom(s) is provided.

13. CUSTOMER COMMENTS

BEKA associates are always pleased to receive comments from customers about our products and services. All communications are acknowledged and whenever possible, suggestions are implemented.

APPENDIX 1 List of plug-in CPU and Input & Output modules.

This appendix lists the plug-in modules available when these instructions were published. Please see BEKA website www.beka.co.uk for any additional modules that may have subsequently been introduced.

CPU Modules

BA3201 Plug-in CPU module without external communication.

BA3202 Plug-in CPU module with Modbus RTU external communication.
The module has an isolated intrinsically safe RS485-IS port and contains software that enables the Operator Panel to operate as a Modbus RTU master or slave.

Input and Output Modules

Model	Function	% of available power module consumes
BA3301	Analogue Input Module 4 x 4/20mA individually isolated unpowered inputs.	4%
BA3401	Digital Input Module 8 x contacts or open collector inputs. 2 combined channels can decode a quadrature input.	4%
BA3402	Digital NAMUR Input Module 8 x NAMUR inputs 2 combined channels can decode a quadrature input.	40%
BA3501	Analogue Output Module 4 x 4/20mA individually isolated unpowered outputs.	4%
BA3601	Digital Output Module 4 x solid state contacts individually isolated.	4%
BA3701	Totaliser / Counter Module 2 x NAMUR inputs each with a synchronous isolated output for retransmission. With both inputs energised	24%

APPENDIX 2 RS485-IS port and network

The BA3202 plug-in CPU module has an isolated RS485-IS port which complies with the requirements of *Profibus RS485-IS User and Installation Guideline Version 1.1/June 2003*.

This guide defines the intrinsic safety parameters for an RS485-IS port as:

U _i	≤	±4.2V
I _i	≤	4.8A
U _o	≤	±4.2V
I _o	≤	149mA
L _i		0
C _i		Not specified for safety, insignificant at 4.2V.
Lo/Ro	≤	15μH/Ω

The standard permits up to 32 devices complying with these safety parameters to be connected to a common 2 wire network located in Zone 1 or 2 with a IIC gas without further system safety analysis.

To prevent reflections both ends of the RS485-IS network should be fitted with terminating resistors if not included in the first and last device. See section A2.2

The RS485-IS port on the BA3202 enables the Pageant Operator Panel to be directly connected to an RS485-IS hazardous area network as shown in Fig. A2.1 and to communicate as a Modbus RTU master or slave.

Each device connected to the network must be certified by a Notified or Approved Body, confirming that the RS485-IS intrinsically safe port complies with the safety parameters specified in the *Profibus RS485-IS User and Installation Guideline*.

Providing not more than 32 devices are connected to the RS485-IS network and the L/R ratio of the network cable is equal to, or less than, 15μH/Ω, no further safety assessment is required. The network cable length does not effect the network intrinsic safety but may effect its performance.

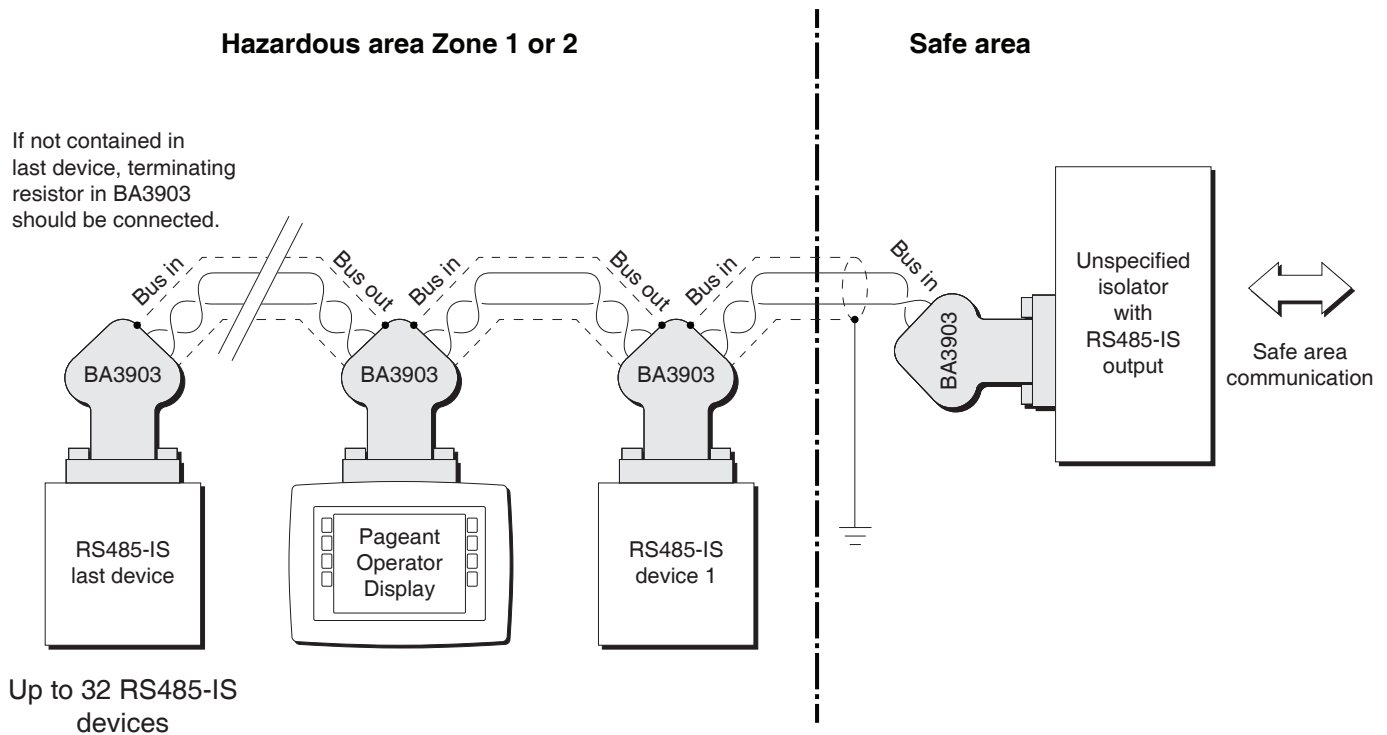

Fig A2.1 Hazardous and safe are network

A2.1 RS485-IS galvanic Isolators

If the hazardous area RS485-IS network is required to communicate with equipment in a safe area, as shown in Fig A2.1, a galvanic isolator with an RS485-IS output port is required to protect the hazardous area network. BEKA associates can provide a list of devices which are known to operate with the Pageant Operator Display and have a variety of safe area network connections.

A2.2 BA3903 connector

The *Profibus RS485-IS User and Installation Guideline* suggests the utilisation of a 9-pole D-Sub female connector for RS485-IS port connections when only IP20 protection is required. Terminating a cable to a D connector is not easy on a process site, therefore BEKA has developed the BA3903 connector.

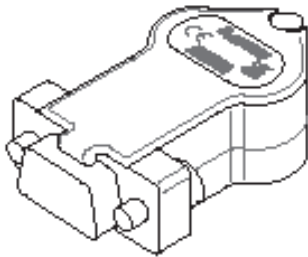

Fig A2.2 BA3903 RS485-IS connector

The BA3903 incorporates a sub D9 male connector that mates with the standard female connector on an RS485-IS field mounting device such as a Pageant plug-in CPU module. The connector can also be used to simplify connection to an RS485-IS galvanic isolator.

Duplicate input and output screw terminals in the BA3903 enable twisted pair field wiring to be easily connected to, and looped-through, the RS485-IS device.

The BA3903 connector also contains a switchable terminating resistor for use at the end of an RS485-IS network.

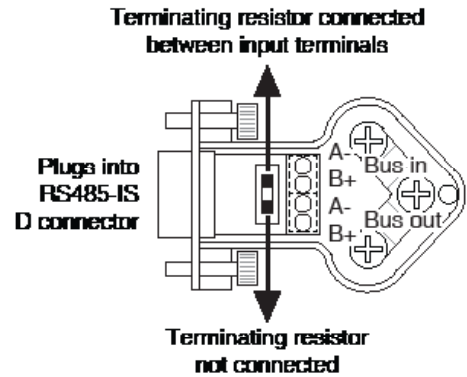

Fig A2.3 Inside BA3903 showing duplicate terminals and switch positions for terminating resistor.



Intrinsic Safe Operator Display
 LCD with adjustable brilliance white backlight
 178mm (7 inch) diagonal 320 x 240 pixels
 8 Touch buttons with tri-colour annunciators.
BA3101 Toughened glass display window
BA3102 Certified impact resistance front panel
 Allows installation in an Ex e or Ex t enclosure without invalidating the enclosure certification



BA3201
CPU without external communication
 Operating system, memory and power distribution
 CODESYS PLC IEC 61131 compliant



BA3202
CPU with Modbus RTU communication
 Operating system, memory and power distribution
 CODESYS PLC IEC 61131 compliant
 Modbus Master or Slave
 Isolated RS485-IS

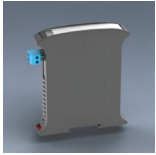

BA212
Power Isolator IIA or IIB applications
 4.4W Typical output
 Safe area or zone 2 mounting
 DIN rail mounting, 22.5mm Wide

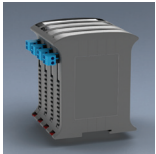

BA243
Power Isolator IIC applications
 4-Channel, combined output 4.4W
 Safe area or zone 2 mounting
 DIN rail mounting, 97mm Wide



BA3901
Power Combiner
 Required for BA243
 Extends cable length for IIC applications
 Mounts onto CPU Module



BA3301
Analogue input module
 4 x 4/20mA inputs
 Individually isolated unpowered inputs
 Consumes 4% of power available for modules



BA3401
Digital input module
 8 x Contact or open collector
 Quadrature decoder using 2 inputs
 Consumes 4% of power available for modules



BA3402
Digital input module
 8 x NAMUR 2 wire proximity detector inputs
 Quadrature decoder using 2 inputs
 Consumes 40% of power available for modules



BA3501
Analogue output module
 4 x 4/20mA outputs
 Individually isolated unpowered outputs
 Consumes 4% of power available for modules

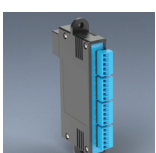

BA3601
Digital output module
 4 solid state contact outputs
 Individually isolated
 Consumes 4% of power available for modules



BA3701
Totaliser/counter module
 2 Non-isolated 2-wire NAMUR inputs
 2 Isolated synchronous pulse outputs
 Consumes 24% of power available for modules



BA3902
USB Programming Cable
 Dedicated to Pageant
 Required to protect IS circuits



BA3903
RS485-IS Connector
 Sub D9 connector
 Required for connecting CPU to RS485-IS comms

SPECIFICATION

Power supply

Voltage 20 to 30Vdc via Power Isolator
 Current Depends on modules fitted 320mA typ.

Certification (typical, see specific data sheet)

IECEX Ex ia IIC T4 Ga
 Ex ia IIIC T135°C Da
 ATEX & UKCA II 1G Ex ia IIC T4 Ga
 II 1D Ex ia IIIC T135°C Da

* Dust certification requires IP54 enclosure

Environmental

Operating Temp -40 to 65°C (Display -20 to 65°C)
 Storage Temp -40 to 85°C
 Humidity to 95% at 40°C non-condensing
 EMC Complies with EMC directive 2014/30/EU

Materials

Display front Flat, easy to clean with bevelled outside edges.
 BA3101 316 stainless steel; 4mm toughened glass
 BA3102 316 stainless steel; 4mm polycarbonate with abrasion resistant outside coating.
 Display rear Flame retardant Noryl
 Power Isolator Flame retardant ABS & Polycarbonate
 Modules Flame retardant Noryl

Ingress Protection

Display IP66 (front) IP20 (rear)
 Modules IP20

Weights

See individual data sheets

DIMENSIONS for BA3101 & BA3102 Operator Display

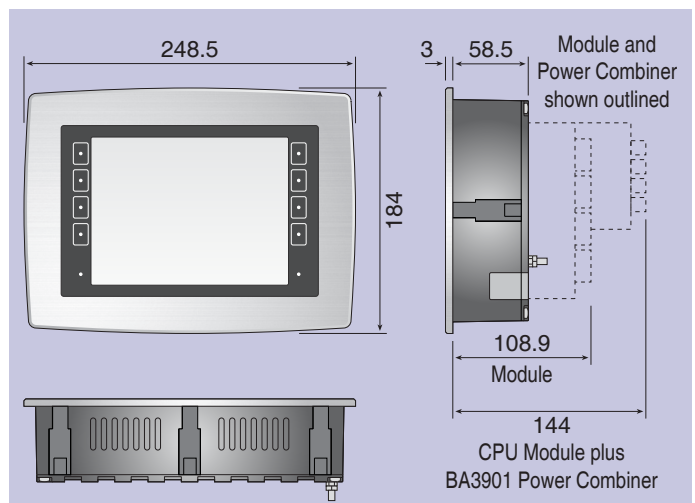

All associated manuals, certificates, and datasheets can be downloaded from
<https://www.beka.co.uk/qr-ba3100>

