

X1-NIS-RLO/SS-05

SIL3 Solid-State Relay Out Module for 2A ND/F&G Loads with Diagnostics

The X1-NIS-RLO/SS-05 solid-state relay module is suitable for switching safety related circuits, up to SIL 3 level, for high risk industries. It provides isolation between input coils and output contacts, making available a safety NO contact for Normally De-energized (ND) or Fire & Gas (F&G) loads. A wide compatibility towards different DCS/PLC is guaranteed: driving pulse testing is permitted by a dedicated internal circuit, which prevents contact and LED flickering, while offering an acceptable resistance to the DO Card. Line and load short/open circuit detection with programmable limits and load voltage monitoring are provided, both when the load is off and when the load is on. The fault in the field is directly mirrored to the PLC DO by artificially increasing the input impedance without commutating the relay contacts, and it is also reported to the cumulative fault. To ease maintenance operations, field devices can be disconnected through a two-position insertion/extraction mechanism. This product requires a dedicated Termination Board.

FEATURES

- SIL 3 / SC 3
- Installation in Zone 2 / Division 2
- Loop disconnection to ease maintenance operations
- Mechanical polarization key to prevent destructive mismatches
- Up to 2 A functional / 6 A inrush current
- Compatible with DCS/PLC pulse testing
- Line & Load short/open circuit detection (programmable thresholds)
- Load voltage monitoring
- Field fault mirroring to the DCS/PLC DO Card
- Automatic TProof test available through Gateway
- Three port isolation, Input/Output/Supply

GATEWAY

X1 Series Gateway family X1-GW makes optional features available. See Instruction Manual for the specific functions available in this model.

ORDERING INFORMATION

Ordering codes

X1-NIS-RLO/SS-05-S: 1 channel

OVERALL DIMENSIONS

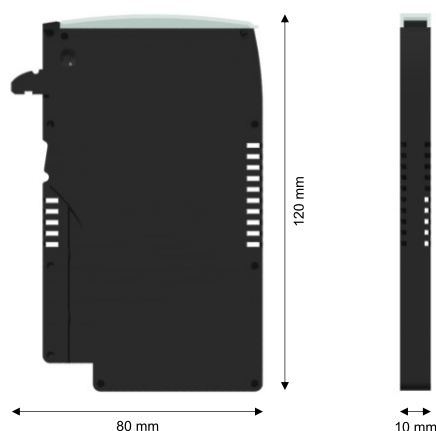

TECHNICAL DATA

General

Power dissipation: 1.1 W @ 24 Vdc System Supply, with 2 A load current, typical.

System Supply

24 Vdc nom (18 to 28.8 Vdc).

Current consumption: 22 mA @ 24 Vdc and relay energized, typical.

System In

24 Vdc nom (18 to 28.8 Vdc).

Current consumption: 12 mA @ 24 Vdc, typical.

Input impedance: 2 kΩ @ 24 Vdc, typical.

Field Supply

DC voltage supply.

Voltage range: 0 to 60 Vdc.

Field Out

ND/F&G load.

Max ratings: 2 A 60 Vdc 120 W.

Max inrush current: 6 A.

Operate / release time: 30 / 30 ms, typical.

Fault

Load & line short/open circuit, supply voltage monitoring.

Line/load fault: programmable resistance (20 Ω to 20 kΩ) and current (20 mA to 2 A) limits.

Load supply voltage ok: ≥ 20 Vdc.

Load supply voltage fault: ≤ 5 Vdc.

Fault signalling: common fault & fault mirroring on DCS/PLC DO.

Response time: ≤ 1 s.

Isolation

Field Out/System In 2.5 kV; Field Out/System Supply 2.5 kV; System In/System Supply 500 V.

Environmental conditions

Operating temperature: temperature limits -40 to +70 °C.

Storage temperature: temperature limits -45 to +80 °C.

Mounting

On custom Termination Board.

Weight: about 60 g.

Dimensions: Width 10 mm, Depth 80 mm, Height 120 mm.

FUNCTION DIAGRAM

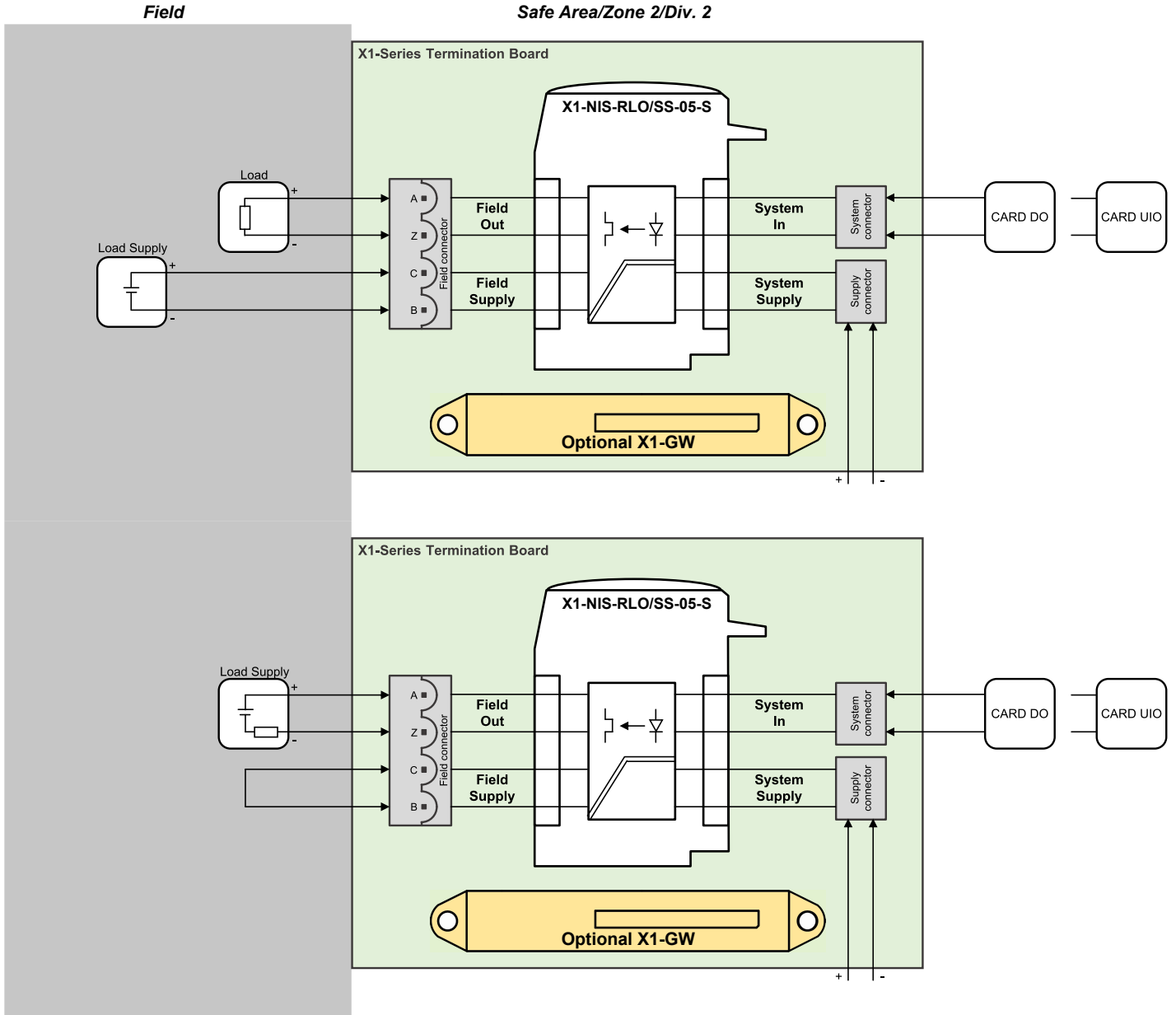

*Additional installation diagrams may be found in Instruction Manual.

Temp. TMP0056 Rev.1

www.gminternational.com

FSM SIL 3 Functional Safety Management Certification: GM International is certified to conform to IEC61508:2010 part 1 clauses 5-6 for safety related systems up to and included SIL3. In addition, GM International products have been granted I.S. certificates from the most credited Notified Bodies in the world.

Data specified in this document are merely descriptive of the products and should be integrated with relevant technical specifications. Our products are in constant development and the information presented herein refers to the time of document issue. No statements concerning a certain condition or suitability for a certain application can be derived from our information. The information given does not release the user from the obligation of own judgment and verification. Terms & Conditions can be found at our website. For more information refer to instruction manual.