

# X1-NIS-RLO/SS-01

## SIL3 Solid-State Relay Out Module for 2A NE Loads

The X1-NIS-RLO/SS-01 solid-state relay module is suitable for switching safety related circuits, up to SIL 3 level, for high risk industries. It provides isolation between input coils and output contacts, making available a safety NO contact for Normally Energized (NE) loads. A wide compatibility towards different DCS/PLC is guaranteed: driving pulse testing is permitted by a dedicated internal circuit, which prevents contact and LED flickering, while offering an acceptable resistance to the DO Card. To ease maintenance operations, field devices can be disconnected through a two-position insertion/extraction mechanism. This product requires a dedicated Termination Board.

### FEATURES

- SIL 3 / SC 3
- Installation in Zone 2 / Division 2
- Loop disconnection to ease maintenance operations
- Mechanical polarization key to prevent destructive mismatches
- Up to 2 A functional / 6 A inrush current
- Compatible with DCS/PLC pulse testing
- Load disconnection on both supply lines available
- Three port isolation, Input/Output/Supply

### ORDERING INFORMATION

#### Ordering codes

X1-NIS-RLO/SS-01-S: 1 channel

### OVERALL DIMENSIONS

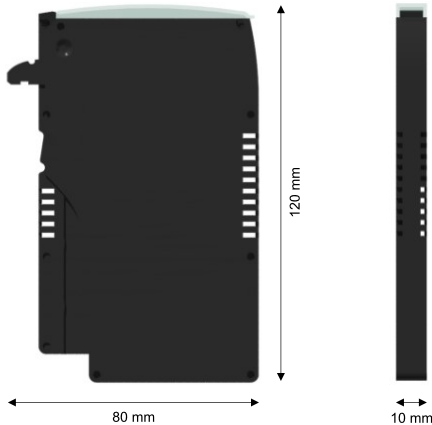

### TECHNICAL DATA

#### General

**Power dissipation:** 1.0 W @ 24 Vdc System Supply, with 2 A load current, typical.

#### System Supply

24 Vdc nom (18 to 28.8 Vdc).

**Current consumption:** 12 mA @ 24 Vdc and relay energized, typical.

#### System In

24 Vdc nom (18 to 28.8 Vdc).

**Current consumption:** 12 mA @ 24 Vdc, typical.

**Input impedance:** 2 kΩ @ 24 Vdc, typical.

#### Field Supply

DC voltage supply.

**Voltage range:** 0 to 60 Vdc.

#### Field Out

NE load.

**Max ratings:** 2 A 60 Vdc 120 W.

**Max inrush current:** 6 A.

**Operate / release time:** 30 / 30 ms, typical.

#### Isolation

System In/Field Out 2.5 kV; System Supply/Field Out 2.5 kV; System In/System Supply 500 V.

#### Environmental conditions

**Operating temperature:** temperature limits -40 to +70 °C.

**Storage temperature:** temperature limits -45 to +80 °C.

#### Mounting

On custom Termination Board.

**Weight:** about 50 g.

**Dimensions:** Width 10 mm, Depth 80 mm, Height 120 mm.

# FUNCTION DIAGRAM

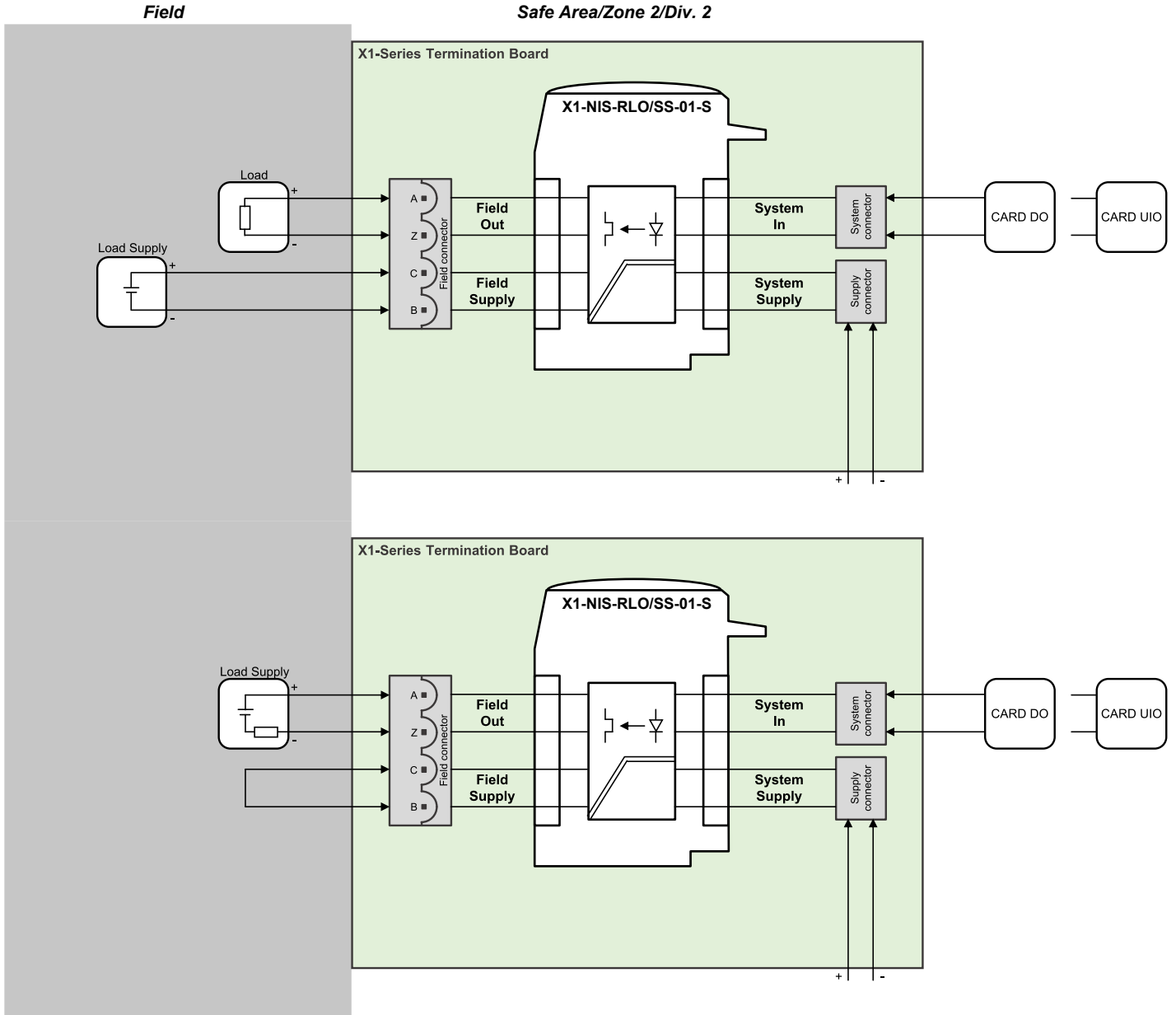

\*Additional installation diagrams may be found in Instruction Manual.

Temp. TMP0056 Rev.1

[www.gminternational.com](http://www.gminternational.com)

**FSM SIL 3** Functional Safety Management Certification: GM International is certified to conform to IEC61508:2010 part 1 clauses 5-6 for safety related systems up to and included SIL3. In addition, GM International products have been granted I.S. certificates from the most credited Notified Bodies in the world.

Data specified in this document are merely descriptive of the products and should be integrated with relevant technical specifications. Our products are in constant development and the information presented herein refers to the time of document issue. No statements concerning a certain condition or suitability for a certain application can be derived from our information. The information given does not release the user from the obligation of own judgment and verification. Terms & Conditions can be found at our website. For more information refer to instruction manual.