

X1-NIS-AI-02

SIL2 2-Wire Passive/Active HART® Tx Current Repeater

The Current Repeater Power Supply X1-NIS-AI-02 module is a high integrity analog input interface suitable for applications requiring SIL 2 level in safety related systems for high risk industries. It provides an isolated supply for energizing conventional two-wire passive 4-20 mA transmitters, while repeating the current to the system card. Two-wire active transmitters are also supported. The circuit allows bi-directional HART® communication for both passive and active devices. The module always sinks current and the Termination Board extends its use to source loops. An out-of-range current fault according to IEC 60947-5-6 NAMUR NE 43 standard is available with limits configurable through the optional Gateway. To ease maintenance operations, field devices can be disconnected through a two-position insertion/extraction lever mechanism. This product requires a dedicated Termination Board.

FEATURES

- SIL 2 / SC 3
- Installation in Zone 2 / Division 2
- Loop disconnection to ease maintenance operations
- Mechanical polarization key to prevent destructive mismatches
- 4-20 mA 2-wire Active-Passive Input
- HART® compatible
- Out-of-range fault according to IEC 60947-5-6 NAMUR NE 43
- Input and Output short circuit proof
- High Accuracy
- Three port isolation, Input/Output/Supply

GATEWAY

X1 Series Gateway family X1-GW makes available HART® Multiplexing and other optional features. See Instruction Manual for the specific functions available in this model.

ORDERING INFORMATION

Ordering codes

X1-NIS-AI-02-S: 1 channel

OVERALL DIMENSIONS

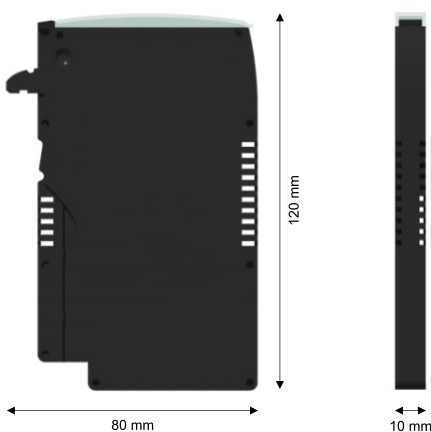

TECHNICAL DATA

General

Power dissipation: 0.55 W (passive Tx), 1.05 W (active Tx) @ 24 Vdc with 20 mA, 24 Vdc + 250 Ω output, typical.

System Supply

24 Vdc nom (18 to 28.8 Vdc).

Current consumption: 23 mA @ 24 Vdc with 20 mA, typical.

System Out

Current 4 to 20 mA. The module always sinks current and the Termination Board extends its use to source loops.

Response time: ≤ 20 ms (4 to 20 mA or 20 to 4 mA).

Current limitation: 26 mA typical.

Maximum load: 600 Ω.

Maximum voltage: 28.8 V.

Minimum voltage: 15 V.

Field In

Current 4 to 20 mA, passive or active Tx.

Passive Tx line voltage: 20 V minimum @ 20 mA.

Active Tx voltage drop: 6.5 V maximum @ 20 mA.

Current limitation: 26 mA typical.

Fault

An out-of-range fault with configurable limits is available on the common fault line.

Performance

Ref. Conditions: 24 V supply, 24 V + 250 Ω output, 23 ± 1 °C ambient temperature.

Accuracy (linearity, calibration and installation): ≤ ± 40 μA within the 4-20 mA range.

Temp. influence: ≤ ± 2 μA/°C.

Isolation

Field In/System Out 2.5 kV; Field In/System Supply 2.5 kV; System Out/System Supply 500 V.

Environmental conditions

Operating temperature: temperature limits -40 to +70 °C.

Storage temperature: temperature limits -45 to +80 °C.

Mounting

On custom Termination Board.

Weight: about 55 g.

Dimensions: Width 10 mm, Depth 80 mm, Height 120 mm.

FUNCTION DIAGRAM

Field

Safe Area/Zone 2/Div. 2

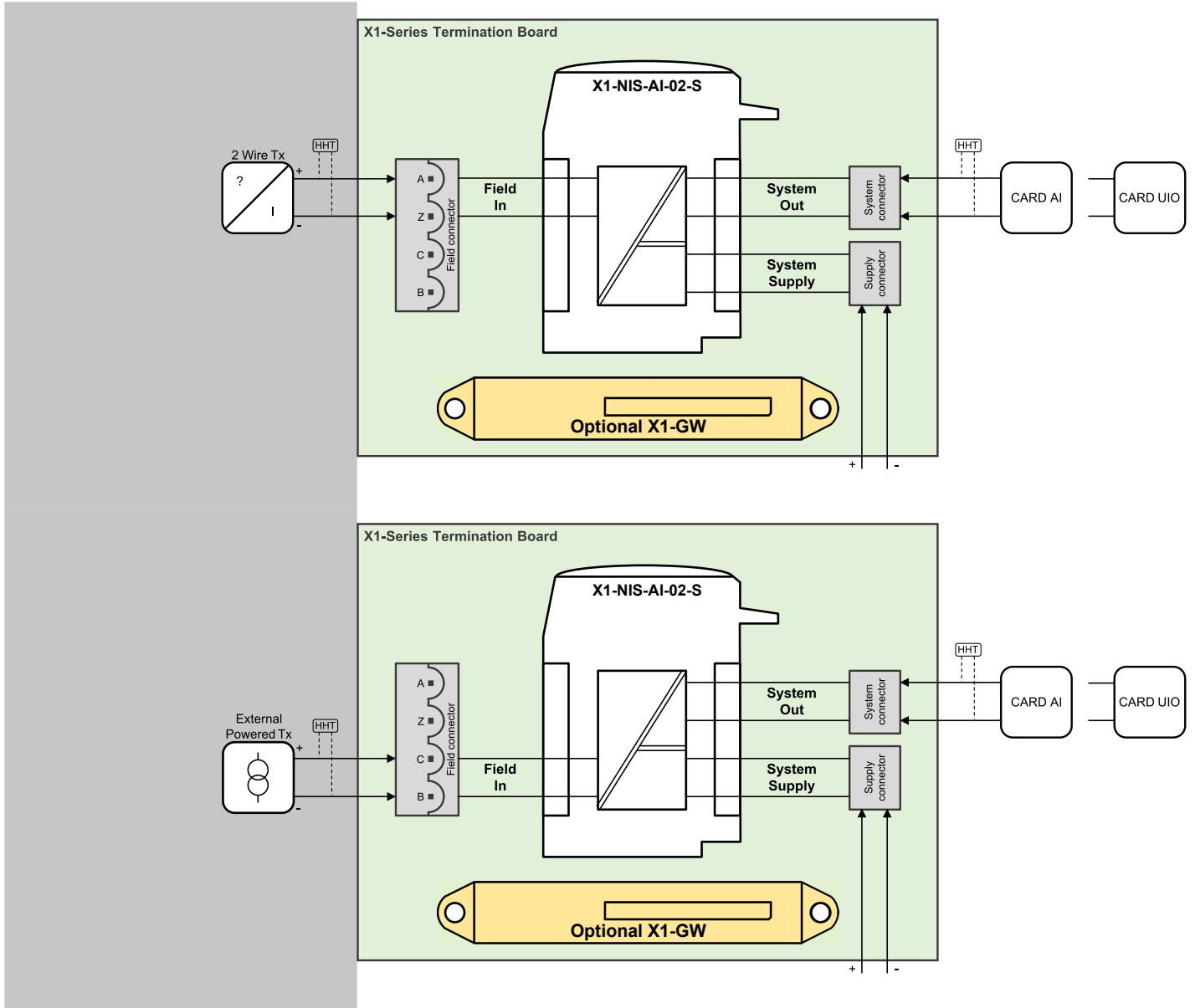

*Additional installation diagrams may be found in Instruction Manual.

Temp. TMP0056 Rev.1

www.gminternational.com

FSM SIL 3 Functional Safety Management Certification: GM International is certified to conform to IEC61508:2010 part 1 clauses 5-6 for safety related systems up to and included SIL3. In addition, GM International products have been granted I.S. certificates from the most credited Notified Bodies in the world.

Data specified in this document are merely descriptive of the products and should be integrated with relevant technical specifications. Our products are in constant development and the information presented herein refers to the time of document issue. No statements concerning a certain condition or suitability for a certain application can be derived from our information. The information given does not release the user from the obligation of own judgment and verification. Terms & Conditions can be found at our website. For more information refer to instruction manual.