

# Manual



**CONFIGURATION**

**INSTALLATION**

**SETUP**

**COMMUNICATION**

**TECHNICAL DATA**



## Manual (ORIGINAL)

---

### Modules with protection class IP20 and increased safety (Ex e)

#### Zone 1/21

- BEx1-PNIO 8AI 8DIO(AO) 8DIO Type: 15200104
- BEx1-Modbus 8AI 8DIO(AO) 8DIO Type: 15200304

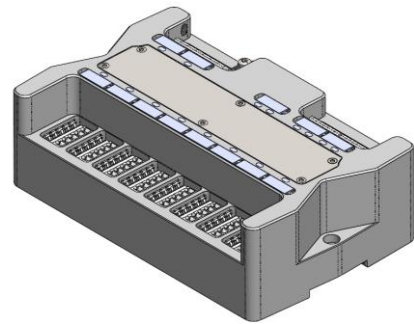

---

### Modules with protection class IP67 and increased safety (Ex e)

#### Zone 1/21

- BEx1-PNIO 8AI 8DIO(AO) 8DIO Type: 15310104
- BEx1-Modbus 8AI 8DIO(AO) 8DIO Type: 15310304

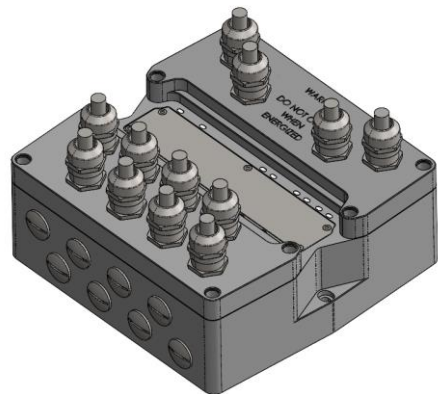

Contact/ Support  
BEx-Solution GmbH  
Lange Strasse 99  
76199 Karlsruhe/Germany  
T: +49 (0) 721 60 90 45 33  
[info@bex-solution.com](mailto:info@bex-solution.com)  
[www.bex-solution.com](http://www.bex-solution.com)

[Link to Product](#)



The original manual is written in German. All other available languages are translations of the original manual.

**Note:** The image picture on the title page is an example of the BEx1

**Reservation:** We reserve the right to make technical changes. Changes, errors or misprints do not constitute a claim for damages.

## Content

1 Important Notes .....	6
1.1 Designated Use.....	6
1.2 Safety Instructions.....	6
1.3 Danger, Warning and Note Symbols .....	6
2 Configuration .....	7
2.1 Power Supply .....	7
2.2 Cable Cross Sections.....	7
2.3 Cable Selection .....	7
2.3.1 Power Supply.....	7
2.3.2 Ethernet .....	7
2.3.3 Sensoren and Actuators .....	7
2.4 Electromagnetic Compatibility (EMC) .....	8
2.5 Grounding.....	8
2.6 Voltage Drops .....	8
3 Description.....	9
3.1 Function.....	9
4 Installation .....	10
4.1 Mounting.....	10
4.2 Abmessungen und Befestigung .....	11
4.3 Connection .....	12
4.3.1 Power supply .....	13
4.3.2 Ethernet .....	13
4.3.3 Sensors and Actuators .....	14
Connection of intrinsically safe sensors and actuators (Ex e terminals), all terminals are equal.	14
5 LED Display.....	15
6 Setup .....	17
7 Diagnostic .....	17
8 Communication Protocols.....	18
8.1 Profinet.....	18
8.1.1 MRP - Media Redundancy Protocol .....	18
8.1.2 LLDP - Link Layer Discovery Protocol.....	18
8.2 Modbus TCP/IP.....	19
8.2.1 IO Register Modbus.....	20
8.2.2 Change the IP Address.....	21
9 IO Daten Profinet.....	22

9.1 Input Byte 0...15 ⇒ Analog Input .....	23
9.2 Input Byte 16...19 ⇒ Digital Input.....	24
9.3 Input Byte 20...23 ⇒ Reserve.....	25
9.4 Input Byte 24...26 ⇒ Interne Spannung .....	25
9.5 Input Byte 27, 28 ⇒ Interne Temperature.....	26
9.6 Input Byte 29...31 ⇒ Operating hour counter.....	26
9.7 Input Byte 32...47 ⇒ Res .....	26
9.8 Input Byte 48 ⇒ Module Diagnoses.....	27
9.9 Input Byte 49...52 ⇒ Open Load .....	28
9.10 Input Byte 53...56 ⇒ Res.....	28
9.11 Input Byte 57...60 ⇒ Short Circuit .....	29
9.12 Input Byte 61...63 ⇒ Serial Number .....	29
9.13 Output Byte 0...15 ⇒ Analog Output .....	30
9.14 Output Byte 16...19 ⇒ Channel ON / OFF .....	31
9.15 Output Byte 21 ⇒ Res.....	31
9.16 Output Byte 22 ⇒ Res.....	31
9.17 Output Byte 23 ⇒ DO to AO (Type *04) .....	32
9.18 Output Byte 20, 24...63 ⇒ Res .....	32
10 Temperature Deratings.....	33
10.1 Power Dissipation .....	34
11 Technical Data.....	35
12 Power Protection X1 bis X8.....	39
13 Explosion Protection.....	40
13.1 Specific Conditions of use for BEx1 .....	40
14 Service, Maintenance .....	41
15 Repair .....	41
16 Disposal .....	41
17 Transport and Storage.....	41
18 Accessories / Spare parts .....	42
19 Troubleshooting.....	43
EU Declaration of Conformity .....	44
List of Abbreviations .....	46
Annex 1 Byte allocation of the different modules .....	47
Annex 2 - How to activate the functions .....	48
Annex 3 Connection examples Type *04 .....	53

# 1 Important Notes

## 1.1 Designated Use

BEx1 module can be installed in hazardous areas of Zone 1/21 and the BEx2 module can be installed in hazardous areas of Zone 2/22.

- For special conditions see chapter 13.

**Read this manual carefully before starting the equipment and keep it in a place that is accessible at any time for all users.** The products described in this manual were developed, manufactured, tested, and documented under strict compliance with safety standards. The equipment poses no danger to operating personnel or material if the handling instructions are complied with. The EU Declaration of Conformity contains the requirements and guidelines that the module fulfills. Trouble-free and safe functioning of the product can only be assured through proper transportation, storage, installation, assembly, and operation with proper care and attention.

## 1.2 Safety Instructions

BEx module may only be operated in a clean, undamaged condition and may only be deployed within the specified temperature class and the temperature range indicated for it (see type label). **The assembly/dismantling of the regulating and control components must be conducted by qualified personnel authorised and trained to install electrical components in potentially explosive areas.** The use in areas other than those specified or alteration of the product releases BEx-Solution from liability for defects and further liability. Modifications and changes to the module are not permitted. The generally applicable statutory regulations and other binding guidelines on occupational health and safety, on accident prevention and on environmental protection must be complied with.

## 1.3 Danger, Warning and Note Symbols

This manual contains important information that has to be observed in order to guarantee safety and avoid material damage. This information is specially marked and illustrated as follows:



### CAUTION

The hazard warning symbol refers to instructions that if not observed, may cause damage to equipment and other objects or, if appropriate precautions are not taken, may result in danger to the user's health or life.



### REMARK

This symbol refers to important technical information



### RECOMMENDATION

Notes with this symbol are recommendations of BEx-Solution GmbH

## 2 Configuration

### 2.1 Power Supply

The electrically operating of the module need 24V (DC 18...30V) direct current voltage. The power supply (SELV/PELV) is connected to the module via Ex e input terminal X9.



**Two independent voltages can be connected (sensor and actuator voltage are separated, with common ground). Therefore it's possible to shut down both in separate**



**It must be ensured that the supply voltage - measured at the farthest module does not fall under 18 V DC. If it does, the module switches off.**

### 2.2 Cable Cross Sections

All terminals on the module are cage clamp terminals (CAGE CLAMP®). The max. cable cross-section at X9 (supply) and X10 (bus) is 2.5 mm<sup>2</sup> and for X1-X8 (sensors and actuators) 2,5 mm<sup>2</sup>.

### 2.3 Cable Selection

#### 2.3.1 Power Supply

Regarding voltage drop the max cable length and cable cross-section must be taken for the power supply cable. A core-cable for fixed installation (max 2.5 mm<sup>2</sup>) is required.

#### 2.3.2 Ethernet

The maximum segment length for electrical data transmission with copper lines between two nodes (field devices or switches) is 100 m. The copper cables should be made uniform in AWG 22. The cable type A should be used. Standard fixed, no movement after installation.

#### 2.3.3 Sensoren and Actuators

Due to intrinsic safety, connecting cables should have the color light blue. A two core-cable for fixed installation (max 2.5 mm<sup>2</sup>) is required. Shielded cable should be used for the analog signals.

## 2.4 Electromagnetic Compatibility (EMC)



Modules confirm to the complete requirements and guidelines of the EU/UK Declaration of Conformity

The modules fulfill the relevant standard of electromagnetic compatibility on its own. There is no guarantee if its installed with other equipment in a plant or machine.

For this reason, we urgently advise you to comply with the instructions on installation in accordance with EMC requirements below. Only then can you assume that the overall system complies with EMC requirements, provided CE-marked components are used exclusively.



**The device is Class A equipment. It may cause radio-frequency interferences in residential areas. In this case, the operator may be required to implement adequate countermeasures.**

## 2.5 Grounding

The earth connection  at the module must be always connected to the necessary equipotential bonding conductor. Required cable cross-section must be minimum 4mm<sup>2</sup>.

## 2.6 Voltage Drops

Short-term voltage drops normally do not pose operational problems as the electronics are protected by capacitors integrated in the power circuits. This does not apply to the power supply of the sensors and actuators connected to the module. Their high-power requirement cannot be covered by the capacitors integrated in the device. For this reason, even transient interruptions of the actuator supply can result in undesirable switching operations. Longer interruptions of the sensor supply may cause changes of the input signal.



## 3 Description

The BEx module is a Remote IO system that is installed as an interface in zone 1/21 in the hazardous area between the increased safety signals from zone 1/21 (sensors/actuators) and the external PLC in the safe area. The system is used to transmit input-output signals via bus system. With BEx module it's possible to connect up to 24 increased safety signals via short cable routes directly to the integrated input/output (IO) module. All signals are combined in the BEx module and digitized via the integrated bus coupler. The data transfer takes place via a four-wire bus cable to the controller.

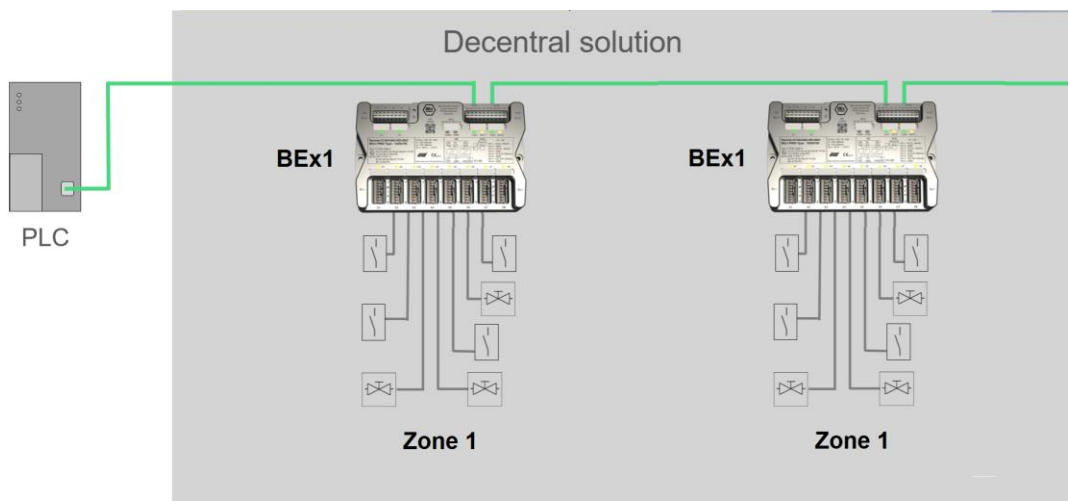

**Figure 1** Simplified display: System and installation with BEx Remote IO module

### 3.1 Function

The module has 24 increased safety channels:

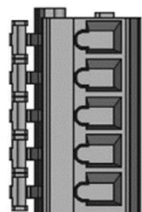
	<b>8AI 8DIO(AO) 8DIO</b>
	Type : 15200*04 (IP20) Type : 15310*04 (IP67)
	(1) AI
	(2) GND
	(3) DI / DO (0.5A) / AO
	(4) GND
	(5) DI / DO (2A)

## 4 Installation



**Danger of explosion**  
**Improperly wired cables/wires can lead to dangerous mix-ups between intrinsically safe and non-intrinsically safe circuits, which can ignite an explosive mixture. Observe the installation instructions acc. IEC/EN 60079-14**

### 4.1 Mounting

**BEx1 IP 20 module** is designed for use in Zone 1/21 hazardous areas and is intended for connection to a fixed installation in certified enclosures/control-stations that conform to equipment protection level Gb or Db. Enclosure type min. IP 54.

**BEx1 IP 67 module** is designed for use in Zone 1/21 hazardous areas and is intended for connection. A second and separate housing is not necessary.

For special conditions see chapter 13.



**Danger of explosion**  
**By incorrect installation, there is a risk of explosion.**

BEx modules can be mounted side by side. The installation position is variable

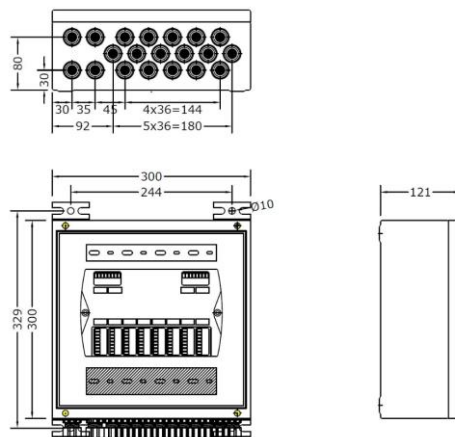

**Figure 2** Example certified Ex e enclosure made of stainless steel with cable glands and shield rail



**RECOMMENDATION: We offer individual certified control stations from our system partner.**

## 4.2 Abmessungen und Befestigung

Typ: 15200\*04

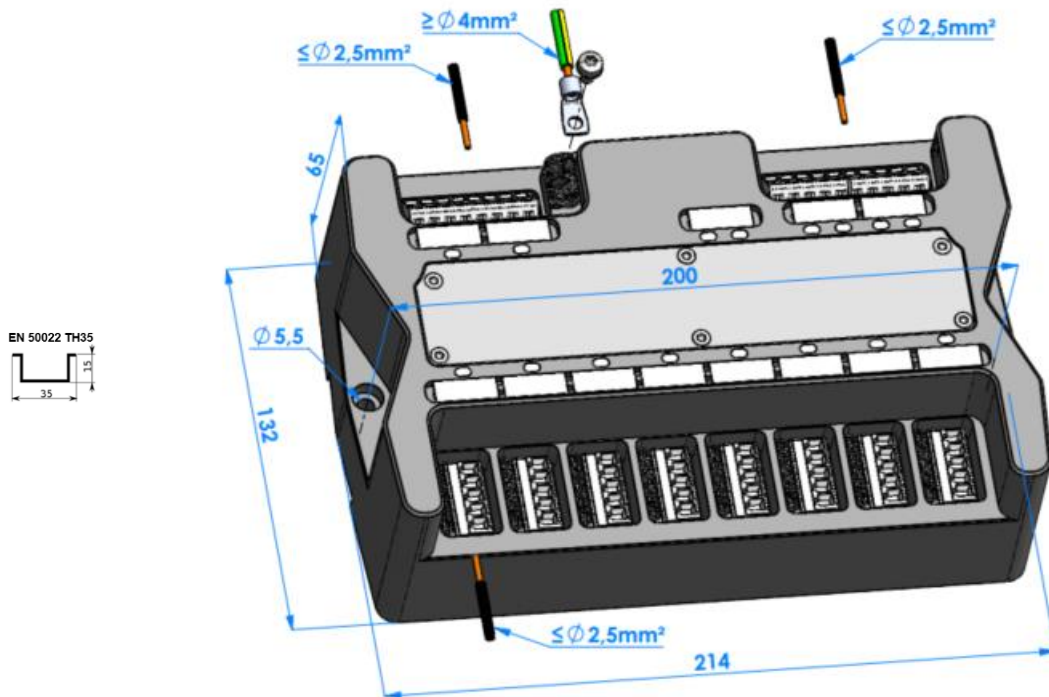

Typ: 15310\*04

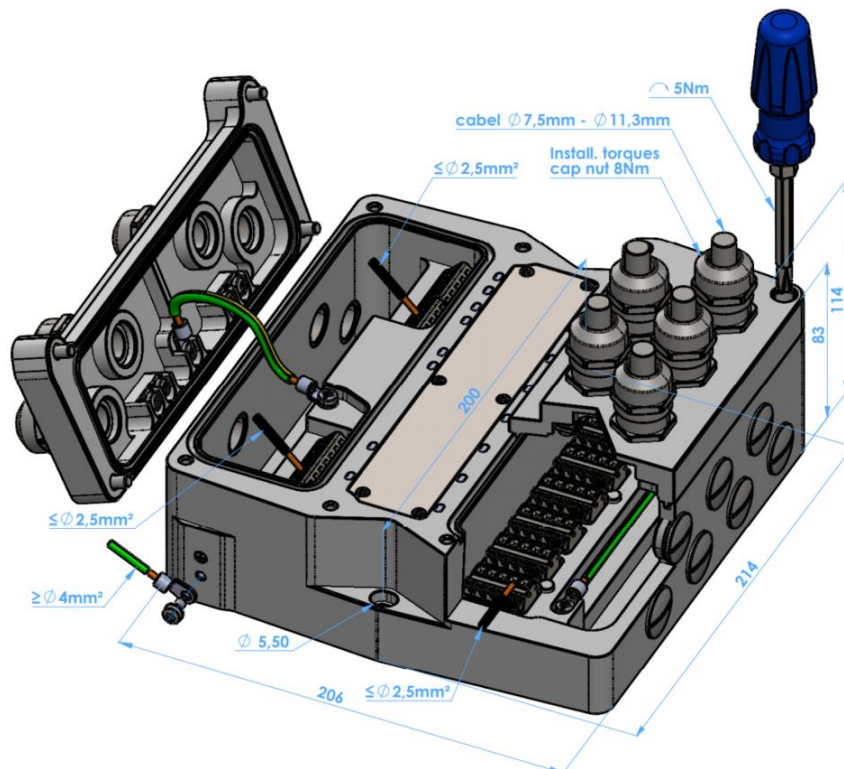

**Figure 3** Dimension and mounting BEx IP20 and IP67 Module

## 4.3 Connection

All terminals are in spring clamp type (CAGE CLAMP®).

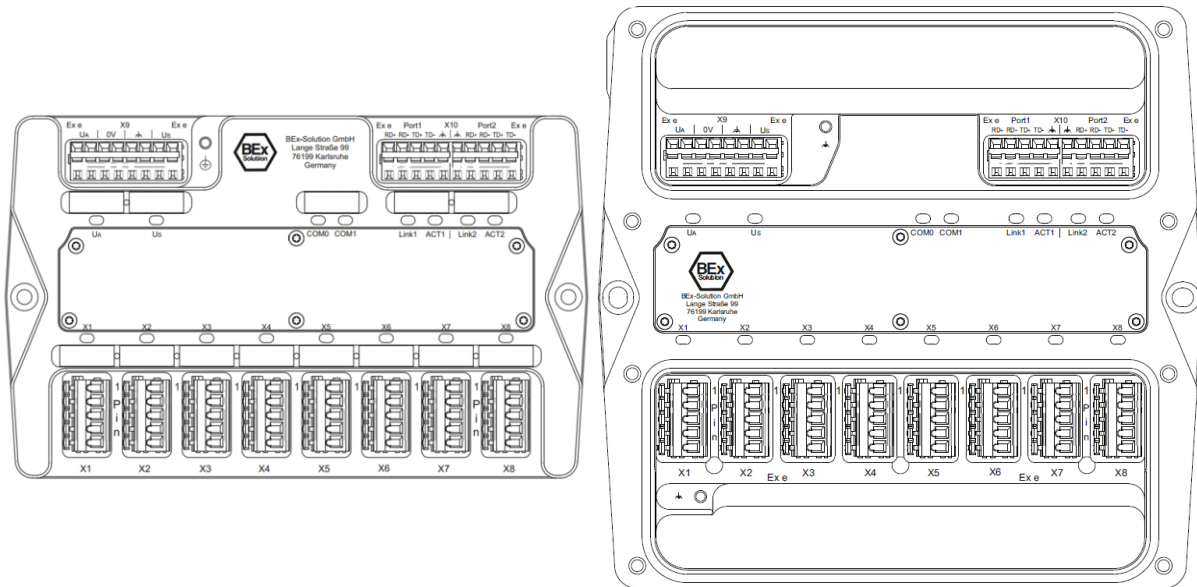

**Figure 4** Front view BEx IP20 und IP67



**Ground connection / equipotential bonding** via M4 screw and eyelet

**X9** **Power supply of actuators, sensors and module**

Ex e terminals (increased safety)

**X10** **Ethernet**

Ex e terminals (increased safety)

**X1-X8** **Intrinsically safe sensors and actuators**

Ex i terminals pluggable (intrinsically safe)

## 4.3.1 Power supply

Power supply of actuators, sensors and module (Ex e terminals)

### Marking terminals:

- UA = Power supply for actuators and sensors
- 0V = Ground
-  = Functional grounding
- US = Power supply for module



**The power supply US must not be switchable. It supplies the module electronics.**

The input voltages US and UA are internally protected against reverse polarity.

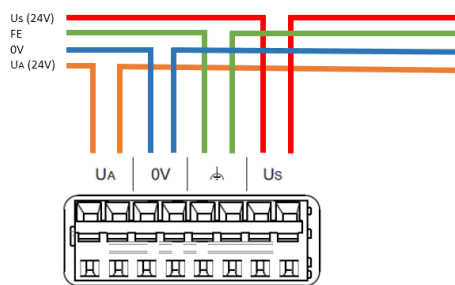

**Figure 5** Terminal X9

## 4.3.2 Ethernet

Ethernet-based fieldbus connection. (Ex e terminals) The integrated switch allows the connection of further bus participants.

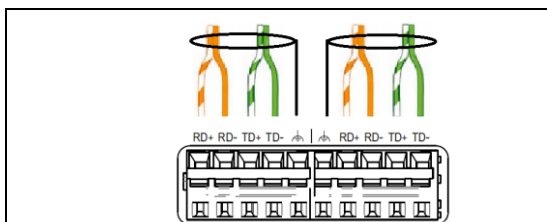

**Figure 6** Terminal X10

RD+	Receive data positive line
RD-	Receive data negative line
TD+	Transmit data positive line
TD-	Transmit data negative line
	Shield



**In the safe area no isolating amplifier for the Ethernet connection is required!**



**Autonegotiation for Ethernet (Layer 1 - OSI-Model) conform with IEEE 802.3u**

**Auto-crossover conform with IEEE 803.2ab**

## 4.3.3 Sensors and Actuators

Connection of intrinsically safe sensors and actuators (Ex e terminals), all terminals are equal.

Marking terminals:

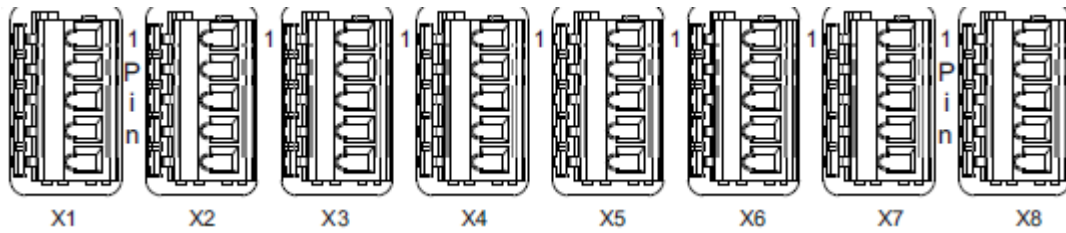

Figure 7 Terminals X1-X8

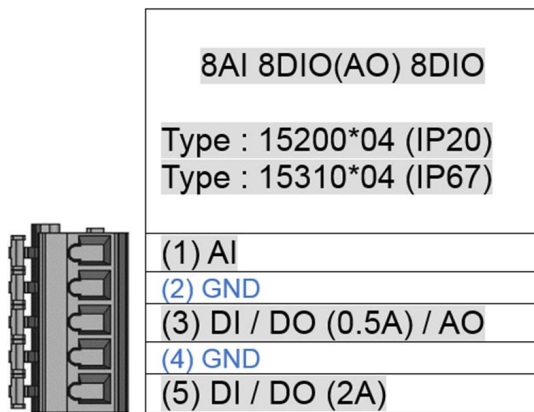

Figure 8 Terminal



**Pin 1 is a passive analog input, Pin 3 and 5 are for active current source**





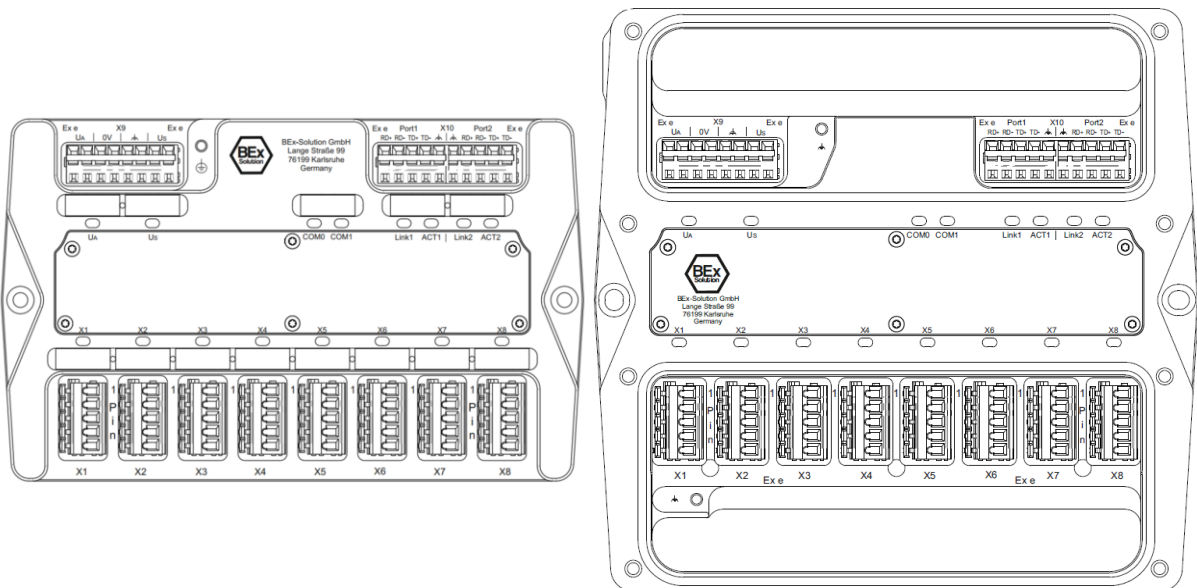









## 5 LED Display

The module is equipped with different LEDs.



**Figure 10** Front view BEx IP20 and IP67

LED	Function	Color
UA	Display of actuator power supply	Green / Red
UA	Display of sensor and module power supply	Green / Red
COM0	Communication LED - 0	Green / Red
COM1	Communication LED - 1	Green / Red
Link1	Ethernet connection LED Port 1	Green
ACT1	Ethernet activity LED Port 1	Yellow
Link2	Ethernet connection LED Port 2	Green
ACT2	Ethernet activity LED Port 2	Yellow
X1-X8	Status display of the associated terminals	Green / Yellow

				Default
UA / US	LED off	No voltage on module		
	LED red	Voltage too low < 18V		
	LED green	Voltage ok U > 18V		←
COM0 / COM1	LED off	Module works property		←
	COM0 LED red	System error		
	COM1 LED red	Bus error		
Link / ACT Each for Port 1 and Port 2	Link / ACT LED off	No connection and no communication		
	Link LED on ACT LED off	Connection exists but no communication		
	Link LED on ACT LED flash	Connection exist Communication in start up	 blitz 	
	Link LED on ACT LED blink ca. 0.5 Hz	Connection exists and communication in operation	 blinkt 	←
X1 to X8	LED off	Output is off and there is no error at the respective terminal		
	LED yellow	Output (pin 7) is switched and there is no error at the respective terminal		
	LED red	There is an error at the respective terminal, regardless of the output		



## 6 Setup

There is no configuration necessary to commission the BEx module.



**Danger of explosion!**  
**Prior to commissioning proper installation must be ensured. See also chapter 1 IMPORTANT NOTES and chapter 4 INSTALLATION!**

## 7 Diagnostic

Open load detection for each channel

Prefault detection for each channel

Short circuit detection for each channel

The corresponding LED-display X1-X8 on the module takes place

The individual messages are available in the communication data

## 8 Communication Protocols

Autonegotiation for Ethernet (Layer 1 - OSI-Model) conform with IEEE 802.3u

Auto-crossover conform with IEEE 803.2ab

### 8.1 Profinet

For operating of Profinet module described in this manual a GSDML-file is required.

GSDML-File \*.xml English

The GSDML file can be downloaded from the website of BEx-Solution:

[www.bex-solution.com/downloads](http://www.bex-solution.com/downloads)

#### 8.1.1 MRP - Media Redundancy Protocol

Please read the complete documentation from Siemens about MRP, here only a small section for the Remote IO module is described, these settings have to be made for every module individually.

The reconfiguration time for MRP is 200ms (for 50 nodes), so the response monitoring time > 200ms must be selected for PROFINET communication. The response monitoring time is not configured directly but as a number of accepted update cycles without IO data. Select IO cycle “can be set”; and enter the desired time. The response monitoring time must be greater than 200ms in total. To achieve this, you can either increase the update time or the number of cycles without PNIO Traffic.

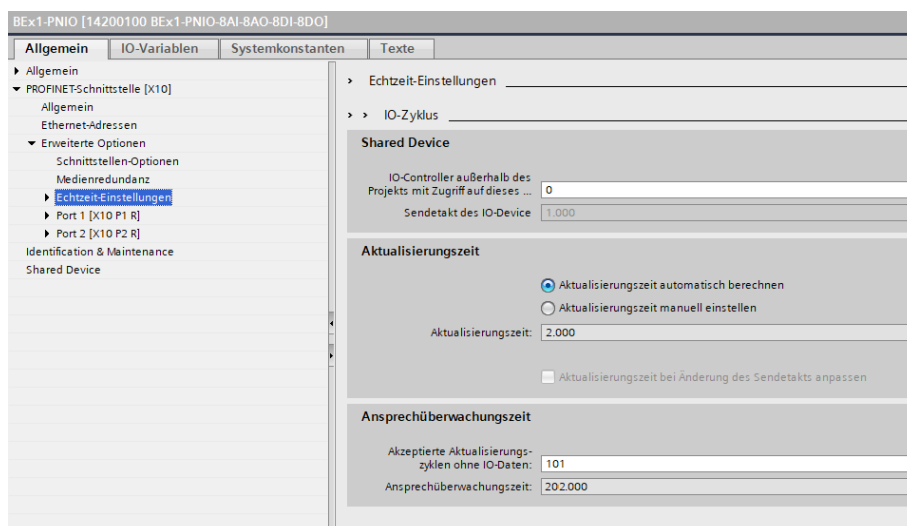

#### 8.1.2 LLDP - Link Layer Discovery Protocol

To use the automatic addressing function (LLDP - conform with IEEE standard 802. 1AB) it is necessary to ensure that:

- The topology recognition in the PLC must turn on.
- If there is a switch in the plant, a managed switch must be used.

## 8.2 Modbus TCP/IP

The module has 32 registers (module → PLC) and 35 registers (PLC → module).

Registers 1-32 correspond to the 64 byte input/output data (see chapter 9)

For a Modbus client whose register numbering begins at 0, the register numbers specified in this manual must be decremented by 1.

Registers 33 to 35 are for addressing the module.



**The NetMask value are fix 255.255.255.0**

Supported MODBUS function codes

Function Code	Register Type
FC2	Read Discrete Input
FC4	Read Input Registers
FC5	Write Single Coil
FC6	Write Single Holding Register
FC15	Write Multiple Coils
FC16	Write Multiple Holding Registers

## 8.2.1 IO Register Modbus

### 32 Register (Modul → SPS)

Register 1		Register 2		Register 3		Register 4		Register 5		Register 6		Register 7		Register 8	
High	Low	High	Low	High	Low	High	Low	High	Low	High	Low	High	Low	High	Low
AI X1 Pin1		AI X2 Pin1		AI X3 Pin1		AI X4 Pin1		AI X5 Pin1		AI X6 Pin1		AI X7 Pin1		AI X8 Pin1	
Register 9		Register 10		Register 11		Register 12		Register 13		Register 14		Register 15		Register 16	
High	Low	High	Low	High	Low	High	Low	High	Low	High	Low	High	Low	High	Low
Res	DI X1-X8 Pin3	DI X1-X8 Pin5	Res	Res	Res	Res	Res	Internal voltage		Internal temperature		Operating hour counter			
								U <sub>S</sub>	U <sub>A</sub>	Res	sign	value			
Register 17		Register 18		Register 19		Register 20		Register 21		Register 22		Register 23		Register 24	
High	Low	High	Low	High	Low	High	Low	High	Low	High	Low	High	Low	High	Low
Res	Res	Res	Res	Res	Res	Res	Res	Res	Res	Res	Res	Res	Res	Res	Res
Register 25		Register 26		Register 27		Register 28		Register 29		Register 30		Register 31		Register 32	
High	Low	High	Low	High	Low	High	Low	High	Low	High	Low	High	Low	High	Low
Modul Diag	Open load			Prefault				Short circuit				Serial number			
	X1-X8 Pin1	X1-X8 Pin3	Res	Res	Res	Res	Res	Res	X1-X8 Pin1	X1-X8 Pin3	X1-X8 Pin5	Res	High	Low	

### 32 Register (SPS → Modul)

Register 1		Register 2		Register 3		Register 4		Register 5		Register 6		Register 7		Register 8	
High	Low	High	Low	High	Low	High	Low	High	Low	High	Low	High	Low	High	Low
High	AO X1	Low	AO X2	High	AO X3	Low	AO X4	High	AO X5	Low	AO X6	High	AO X7	Low	AO X8
Register 9		Register 10		Register 11		Register 12		Register 13		Register 14		Register 15		Register 16	
High	Low	High	Low	High	Low	High	Low	High	Low	High	Low	High	Low	High	Low
ON/OFF X1-X8 Pin 1	ON/OFF X1-X8 Pin 3	ON/OFF X1-X8 Pin 5	Res	Res	Switch mode X1-X8 Type *00 Pin 1-3 Type *01 Pin 1-2	AO->DO X1-X8 Type *00 Pin 3	DO->AO X1-X8 Type *01 Pin 1 Type *04 Pin 3	DO->AI X1-X8 Type *01 Pin 1	Res	Res	Res	Res	Res	Res	Res
Register 17		Register 18		Register 19		Register 20		Register 21		Register 22		Register 23		Register 24	
High	Low	High	Low	High	Low	High	Low	High	Low	High	Low	High	Low	High	Low
Res	Res	Res	Res	Res	Res	Res	Res	Res	Res	Res	Res	Res	Res	Res	Res
Register 25		Register 26		Register 27		Register 28		Register 29		Register 30		Register 31		Register 32	
High	Low	High	Low	High	Low	High	Low	High	Low	High	Low	High	Low	High	Low
Res	Res	Res	Res	Res	Res	Res	Res	Res	Res	Res	Res	Res	Res	Res	Res

Alle „Res“ Bytes müssen auf „0“ stehen. Die Kanäle können über die Bytes 16 bis Byte 18 eingeschaltet werden!

## 8.2.2 Change the IP Address

Register 33 : IP-Address\_Byte1 and IP-Address\_Byte0

Register 34 : IP-Address\_Byte3 and IP-Address\_Byte2

Register 35 : Flag for writing or DHCP

IP-Byte1	IP-Byte0	IP-Byte3	IP-Byte2	Flag (Write or DHCP)
Register 33		Register 34		Register 35
IP Address		IP Address		Flag

Writing 0xFEEF to the register „Flag“, the values in register 33 and 34 will be stored in the module.

Writing 0xA55A to the register "Flag", will delete the stored IP Address and activate DHCP.

After storing the IP-Address the module does a reset.

Example for IP Address: **192.168.1.68**

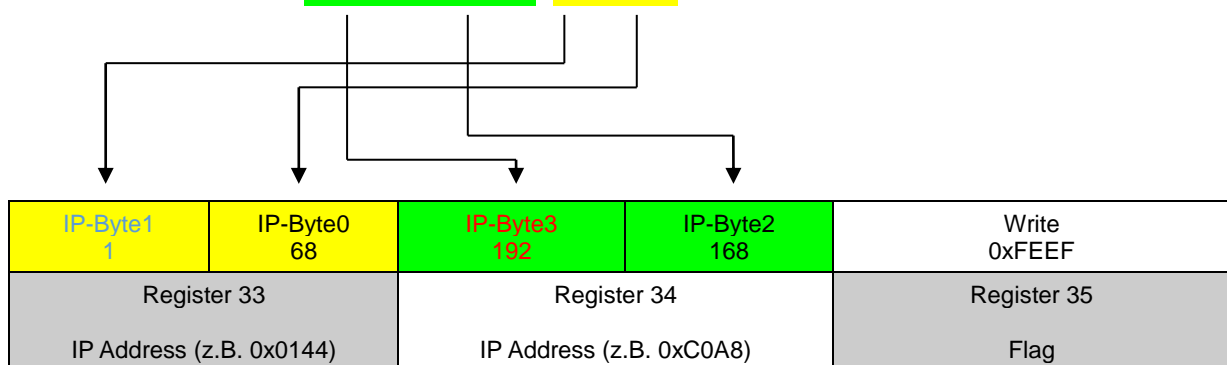

Register 33 : 0x0144 -> (IP\_B0 : 68 = hex 44 ; IPB1 : 1 = hex 01)

Register 34 : 0xC0A8 -> (IP\_B2 : 168 = hex A8 ; IPB3 : 192 = hex C0)

Register 35 : 0xFEEF (write)

## 9 IO Daten Profinet

64 Input byte – (Modul → SPS)

0	1	2	3	4	5	6	7	8	9	10	11	12	13	14	15
High AI X1 Pin1	Low	AI X2 Pin1	AI X3 Pin1	AI X4 Pin1	AI X5 Pin1	AI X6 Pin1	AI X7 Pin1	AI X8 Pin1							

16	17	18	19	20	21	22	23	24	25	26	27	28	29	30	31
Res	DI X1-X8 Pin3	DI X1-X8 Pin5	Res	Res	Res	Res	Res	Internal voltage			Internal temperature		High Operating hour counter Low		
								U <sub>S</sub>	U <sub>A</sub>	Res	sign	value			

32	33	34	35	36	37	38	39	40	41	42	43	44	45	46	47
Res	Res	Res	Res	Res	Res	Res	Res	Res	Res	Res	Res	Res	Res	Res	Res

48	49	50	51	52	53	54	55	56	57	58	59	60	61	62	63
Modul Diag	Open load			Prefault				Short circuit				High Serial number Low			
	X1-X8 Pin1	X1-X8 Pin3	Res	Res	Res	Res	Res	Res	X1-X8 Pin1	X1-X8 Pin3	X1-X8 Pin5	Res			

64Output byte – (SPS → Modul)

0	1	2	3	4	5	6	7	8	9	10	11	12	13	14	15
High AO X1	Low	AO X2	AO X3	AO X4	AO X5	AO X6	AO X7	AO X8							

16	17	18	19	20	21	22	23	24	25	26	27	28	29	30	31
ON/OFF X1-X8 Pin 1	ON/OFF X1-X8 Pin 3	ON/OFF X1-X8 Pin 5	Res	Res	Switch mode X1-X8 Type *00 Pin 1-3 Type *01 Pin 1-2	AO->DO X1-X8 Type *00 Pin 3	DO->AO X1-X8 Type *01 Pin 1 Type *04 Pin 3	DO->AI X1-X8 Type *01 Pin 1	Res	Res	Res	Res	Res	Res	Res

32	33	34	35	36	37	38	39	40	41	42	43	44	45	46	47
Res	Res	Res	Res	Res	Res	Res	Res	Res	Res	Res	Res	Res	Res	Res	Res

48	49	50	51	52	53	54	55	56	57	58	59	60	61	62	63
Res	Res	Res	Res	Res	Res	Res	Res	Res	Res	Res	Res	Res	Res	Res	Res

All „Res“ Bytes have to be „0“. The channels can be switched on via bytes 16 to byte 19!

## Explanation:

- AI** = Analog Input
- AO** = Analog Output
- DI** = Digital Input
- DO** = Digital Output
- Res** = Reserved (do not use)
- Diag** = Diagnoses

## 9.1 Input Byte 0...15 ⇔ Analog Input

Value :1000 = analog Value in mA (z.B. 9987 : 1000 = 9,987mA)

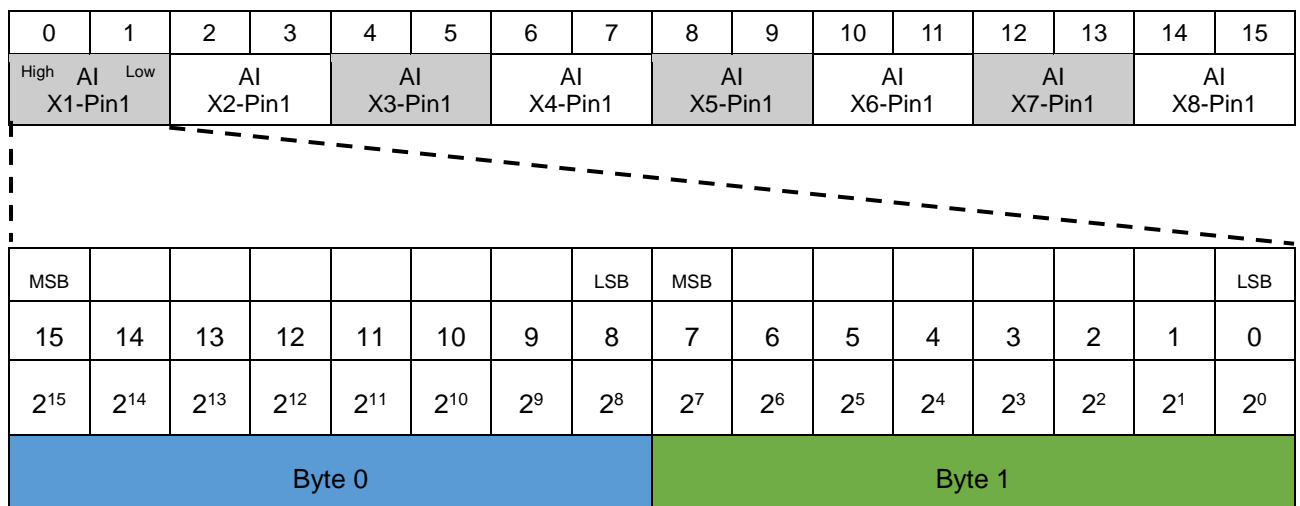

For example:

Value[mA]	hex		dex	
4,000	0F	A0	15	160
10,000	27	10	39	16
15,000	3A	98	58	152
20,000	4E	20	78	32
25,000	61	A8	97	168
	Byte 0	Byte 1	Byte 0	Byte 1

## 9.2 Input Byte 16...19 ⇒ Digital Input

Input Byte 16 ⇒ Res  
 Input Byte 17 ⇒ X1...X8 - Pin 3  
 Input Byte 18 ⇒ X1...X8 - Pin 5  
 Input Byte 19 ⇒ Res

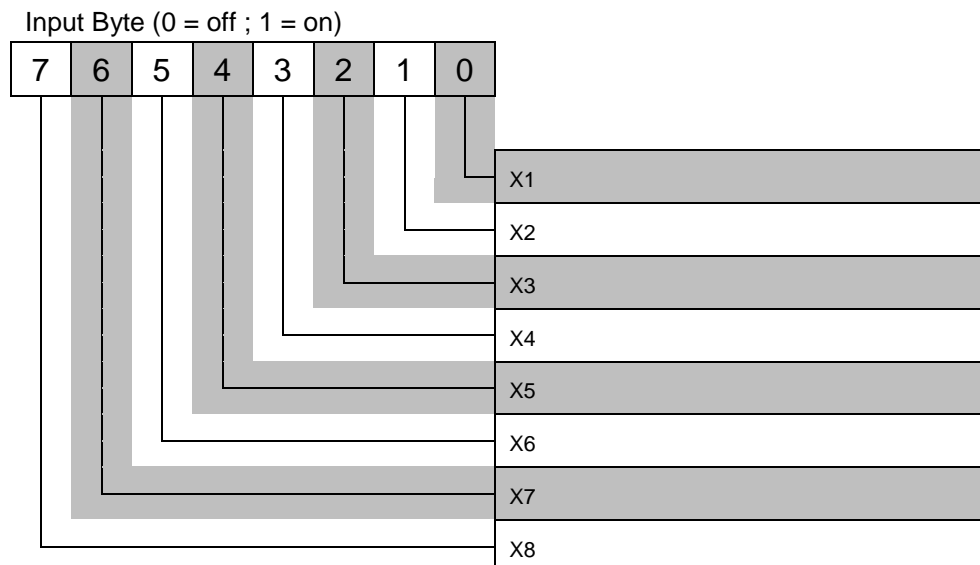

„0“ if current is < 3 mA

„1“ if current is > 5 mA

Current from max. value ⇒ Short circuit, max. current



## 9.3 Input Byte 20...23 ⇒ Reserve

Do not use

## 9.4 Input Byte 24...26 ⇒ Interne Spannung

Input Byte 24 ⇒  $U_s$     Internal Sensor supply voltage  
Input Byte 25 ⇒  $U_A$     Internal Actuator supply voltage  
Input Byte 26 ⇒ Res

Value :10 = Voltage value in V

z.B. 243 : 10 = 24,3V

The voltage is measured with a tolerance of  $\pm 10\%$ .

## 9.5 Input Byte 27, 28 ⇒ Interne Temperature

Input Byte 27 ⇒ Sign of temperature

Input Byte 28 ⇒ Temperature value

Byte 27 = Sign of temperature value in Byte 28

(0 = positive temperature value; 1 = negative temperature value)

Byte 28 = Temperature value in °C (e.g. 24 = 24°C)

if Byte 27 = 1 then e.g. -24°C

The temperature is measured with a tolerance of  $\pm 5K$ .

If the temperature rises internally above 75 ° C (or < 45 ° C) there will be an outcoming error message on byte 48.

## 9.6 Input Byte 29...31 ⇒ Operating hour counter

Input Byte 29 ⇒ High value

Input Byte 30 ⇒ Mid value

Input Byte 31 ⇒ Low value

Value = operating hour in h

e.g. 7488 : 24 = 312 days

## 9.7 Input Byte 32...47 ⇒ Res

## 9.8 Input Byte 48 ⇒ Module Diagnoses

Input Byte 48 ⇒ Any module diagnoses appear in this byte

Modul Diagnose (0 = OK ; 1 = Fault)

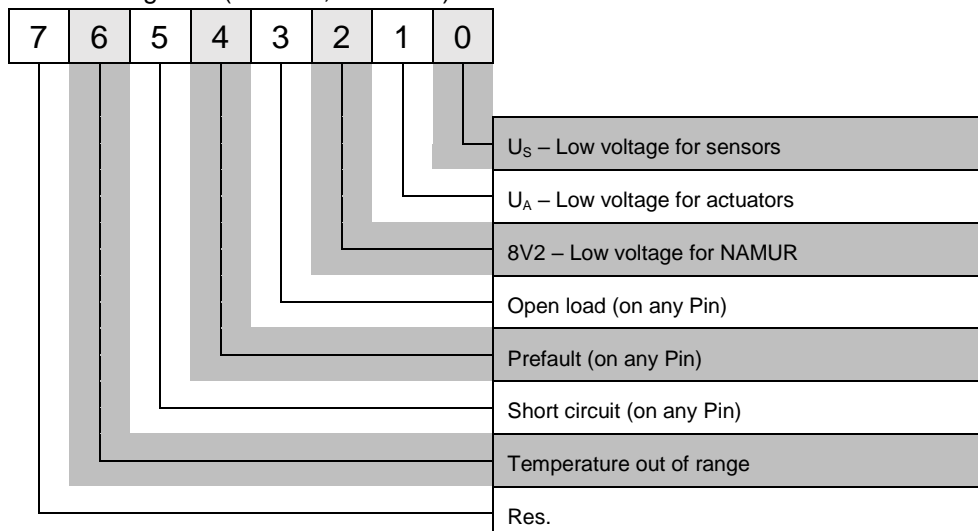

### RECOMMENDATION:

All errors are displayed in this byte and should be evaluated in the PLC.

## 9.9 Input Byte 49...52 ⇒ Open Load

- Input Byte 49 ⇒ Open load Pin 1
- Input Byte 50 ⇒ Open load Pin 3
- Input Byte 51 ⇒ Res
- Input Byte 52 ⇒ Res

Open load Byte 49 (0 = OK ; 1 = Fault)

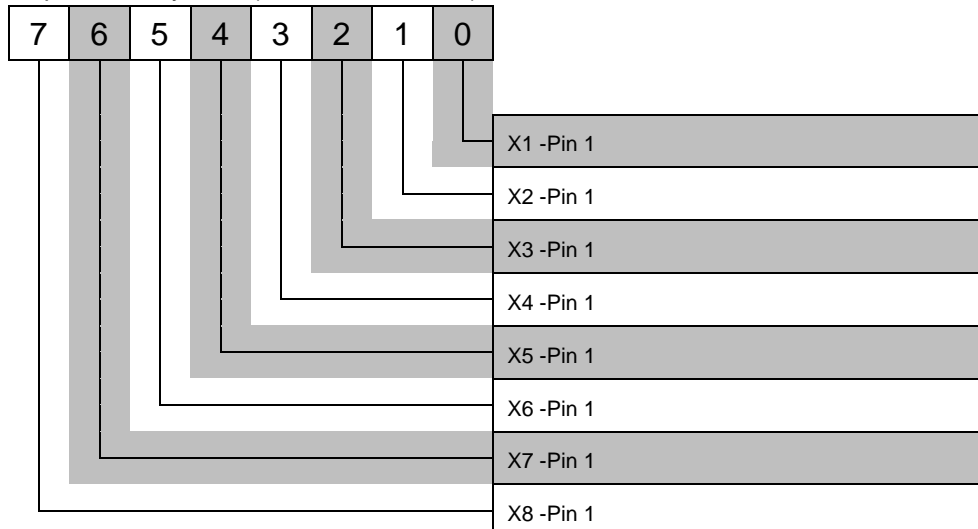

Open load is detected at a current < 3,6 mA

## 9.10 Input Byte 53...56 ⇒ Res

## 9.11 Input Byte 57...60 ⇒ Short Circuit

Input byte 57 ⇒ Short circuit Pin 1 ( $I > 24\text{mA}$ )

Input byte 58 ⇒ Short circuit Pin 3

Input byte 59 ⇒ Short circuit Pin 5

Input byte 60 ⇒ Res

Short circuit Byte 57 (0 = OK ; 1 = Fault)

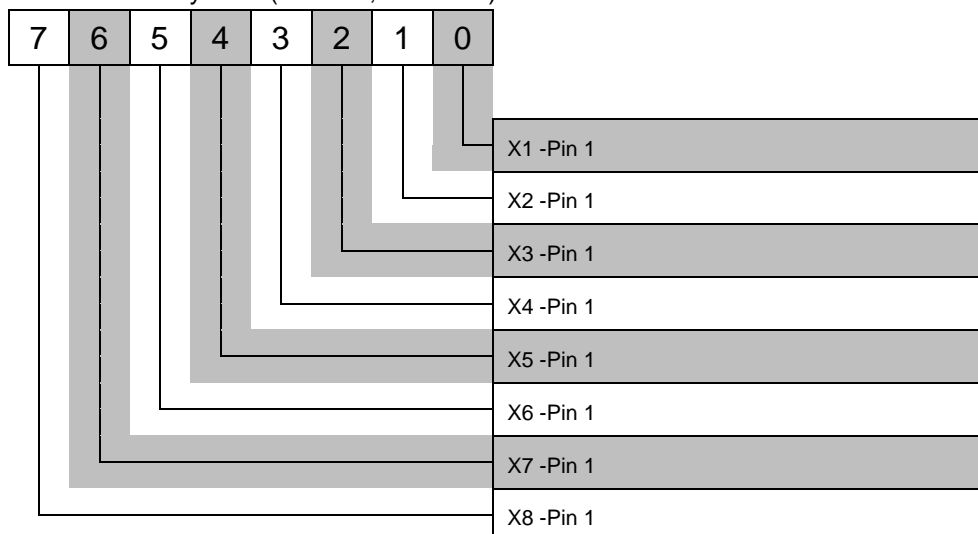

## 9.12 Input Byte 61...63 ⇒ Serial Number

Input Byte 61 ⇒ High value

Input Byte 62 ⇒ value

Input Byte 63 ⇒ Low value

Value = Serial number

Value > 100000

## 9.13 Output Byte 0...15 ⇒ Analog Output

- Output Byte 0, 1 ⇒ analog Output 0
- Output Byte 2, 3 ⇒ analog Output 1
- Output Byte 4, 5 ⇒ analog Output 2
- Output Byte 6, 7 ⇒ analog Output 3
- Output Byte 8, 9 ⇒ analog Output 4
- Output Byte 10, 11 ⇒ analog Output 5
- Output Byte 12, 13 ⇒ analog Output 6
- Output Byte 14, 15 ⇒ analog Output 7

Wert :1000 = analoge value in mA (z.B. 9987 : 1000 = 9,987mA)

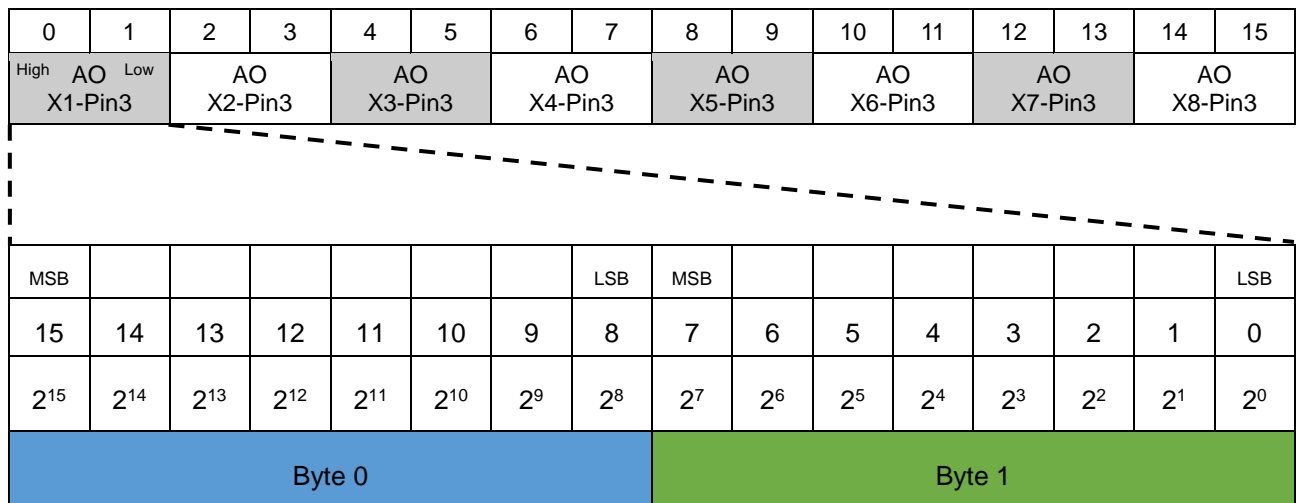

For example:

Value[mA]	hex		dex	
4,000	0F	A0	15	160
10,000	27	10	39	16
15,000	3A	98	58	152
20,000	4E	20	78	32
25,000	61	A8	97	168
	Byte 0	Byte 1	Byte 0	Byte 1

## 9.14 Output Byte 16...19 ⇒ Channel ON / OFF

Output Byte 16 ⇒ Channel ON / OFF on Pin 1  
 Output Byte 17 ⇒ Channel ON / OFF on Pin 3  
 Output Byte 18 ⇒ Channel ON / OFF on Pin 5  
 Output Byte 19 ⇒ Res

Channel ON/OFF Byte 16 (0 = ON ; 1 = OFF)

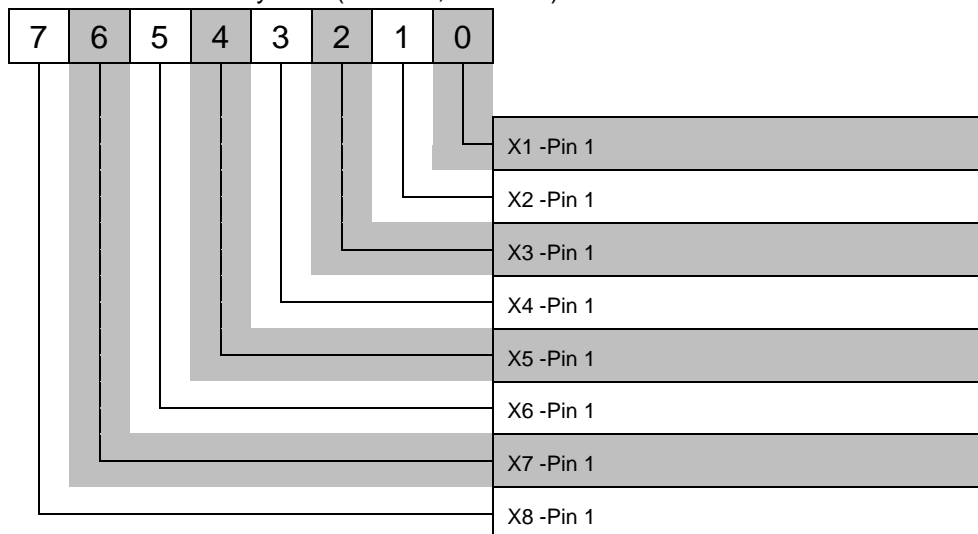

The channels can be switched on via bytes 16 to byte 18!  
**To turn on the function of Pin 1, 3, 5, 7 the bytes 16 to 18 are always set to "1". The DO function can be turned on and off via this Bytes.**



A short circuit at DO or at DI leads to the immediate shutdown of the affected pin. Every 5 seconds, it is checked whether the short circuit is still present. Only when the error has been corrected, the pin automatic switch on.

## 9.15 Output Byte 21 ⇒ Res

## 9.16 Output Byte 22 ⇒ Res

## 9.17 Output Byte 23 ⇒ DO to AO (Type \*04)

Output Byte 23 ⇒ DO -> AO ON/OFF (default = 0 = DO)

Digital Mode ON/OFF Byte 23 (1 = ON; 0 = OFF)

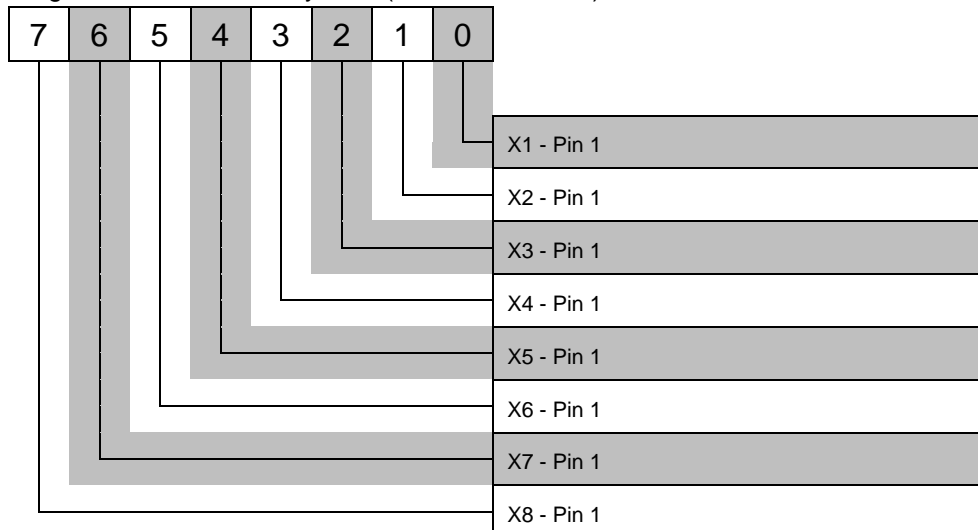

Pin 3 can be use for DO(I<sub>max</sub>=0,5A), AO(I<sub>max</sub> = 25mA) or DI.

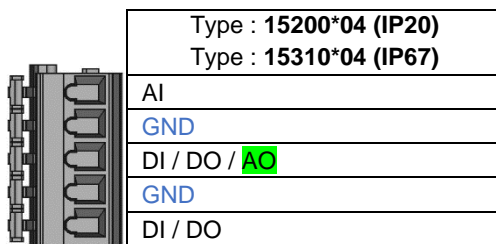

## 9.18 Output Byte 20, 24...63 ⇒ Res

All „Res” bytes or bytes where not in use have to set to “0”



## 10 Temperature Deratings

Number of simultaneously usable channels.

Not all channels may be used at the same time, if the service temperature will rise > 50°C.

The actual temperature value are transferred via the communication data.

	40°C	50°C	60°C	70°C
AI	8	8	8	8
AO	8	8	5	2
DI	8	8	8	8
DO	8	8	5	2

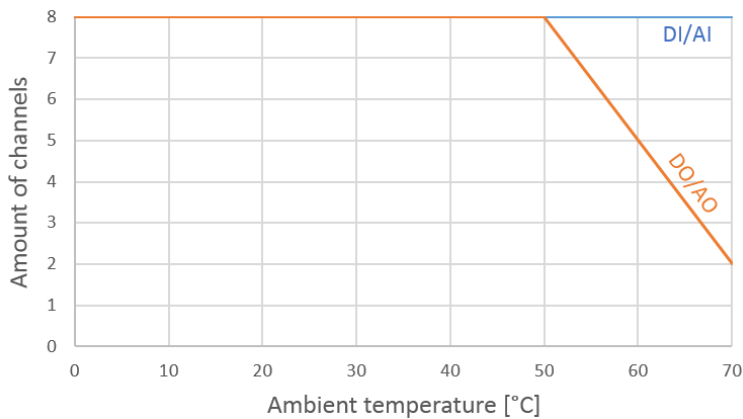

The device is equipped with a temperature monitoring and measures permanently the operating temperature. If the operating temperature of module exceeds 75°C, an error message is displayed in the communication data and at 85°C all output channels and the communication are switched off.



**The module automatically does switch back to operating mode, as soon as the operating temperature has reached a value < 75°C.**

## 10.1 Power Dissipation

### Type \*04

Power Dissipation max. 15 W

Calculation Power Dissipation:

Idling: 5 W

## 11 Technical Data

### BEx Remote IO module for Ex e Zone 1

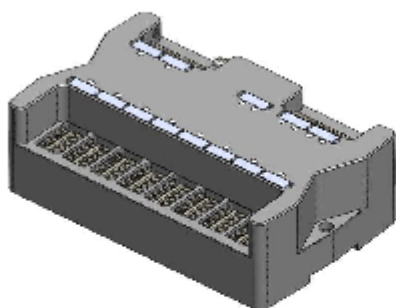

or



Compact Remote IO modules for Ex Zone 1 with Profinet or Modbus TCP/IP.

The modules include busnode with **24 increased safety** digital IO channels on smallest space.

**BEx1** module can be installed in Zone 1 with certified Ex e enclosure and connects sensors and actuators from Zone 1.

#### Feature

- Fully potted → extreme robust
- IO variations  
8AI 8DIO(AO) 8DIO
- None configuration on module required
- Galvanic separation between channel and system
- Internal temperature monitoring
- Operating hour counter

#### BEx1 Explosion protection

EPS 19 ATEX 1 219 X  
 EPS 22 UKEX 1 045 X  
 II 2 G Ex eb mb IIC T4 Gb  
 IECEx EPS 19.0093X  
 Ex eb mb IIC T4 Gb

#### Power supply

Operation voltage $U_A/U_S$	DC 18...30V
Current module and sensor supply $I_S$	DC 450 mA
Current actuator supply $I_A$	DC 12A
Power dissipation	max. 15 W
Reverse polarity protection	Yes
LED Voltage > 18V	Green
LED Undervoltage	Red

#### Fieldbus data

Addressing Profinet	via DCP
Addressing Modbus TCP/IP	DHCP or fix
Transfer Rate	10/100 MBit/s
Delay in signal change	< 10ms
LED Ethernet status LINK	Green
LED Ethernet status ACT	Yellow
LED Modul status	Green / Red
LED digital output on	Yellow
LED error detection	Red

#### Ambient conditions

Range of the service temperature after installation inside	
additional enclosure	-40°C ... +70°C
Storage temperature	-40°C ... +80°C
Enclosure type (EN 60529)	IP 20

#### Mechanical data

Dimensions (LxWxH)	214 x 132 x 85 mm
Mounting holes	Ø 5,2
Mounting space	200 mm
Mounting position	any position
Weight	approx. 2700 g
Housing material	Aluminium (electroplated)
Housing marking	laser engraving

## BEx1 IO module IP67 Ex e for Zone 1/21

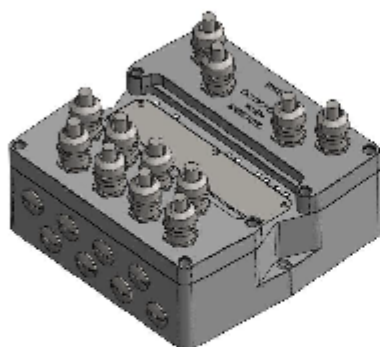

or



Compact Remote IO module for Ex Zone 1/21 with Profinet or Modbus TCP/IP. The module include busnode with **24 increased safety** digital IO channels on smallest space.

**BEx1** module can be installed directly in Zone 1/21 and connects sensors and actuators from Zone 1/21.

### Feature

- Fully potted → extreme robust
- IO variations  
8AI 8DIO(AO) 8DIO
- None configuration on module required
- Galvanic separation between channel and system
- Internal temperature monitoring
- Operating hour counter

### BEx1 Explosion protection

EPS 19 ATEX 1 219 X  
 EPS 22 UKEX 1 045 X  
 II 2 G Ex eb mb IIC T4 Gb  
 II 2 D Ex tb IIIC T110°C Db  
 IECEx EPS 19.0083X  
 Ex eb mb IIC T4 Gb  
 Ex tb IIIC T110°C Db

### Power supply

Operation voltage U <sub>0</sub> /U <sub>s</sub>	DC 18...30V
Current module and sensor supply I <sub>s</sub>	DC 450 mA
Current actuator supply I <sub>A</sub>	DC 12A
Power dissipation	max. 15 W
Reverse polarity protection	Yes
LED Voltage > 18V	Green
LED Undervoltage	Red

### Fieldbus data

Addressing Profinet	via DCP
Addressing Modbus TCP/IP	DHCP or fix
Transfer Rate	10/100 MBit/s
Delay in signal change	< 10ms
LED Ethernet status LINK	Green
LED Ethernet status ACT	Yellow
LED Modul status	Green / Red
LED digital output on	Yellow
LED error detection	Red

### Ambient conditions

Operating temperature	-40°C ... +70°C
Storage temperature	-40°C ... +80°C
Enclosure type (EN 60529)	IP66 / IP67

### Mechanical data

Dimensions (LxWxH)	214 x 206 x 115mm
Mounting holes	∅ 6,5
Mounting space	200 mm
Mounting position	any position
Weight	approx. 5400 g
Housing material	Aluminium (electroplated)
Housing marking	laser engraving
Vibration (EN 60068)	20g
Shock (EN 60068)	50g
Cable glands stainless steel	M20x1,5

## IO - Funktionen

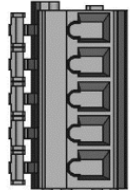
	<b>8AI 8DIO(AO) 8DIO</b>
	Type : 15200*04 (IP20)
	Type : 15310*04 (IP67)
	(1) AI
	(2) GND
(3) DI / DO (0.5A) / AO	
(4) GND	
(5) DI / DO (2A)	

DI .....	24V (I > 5mA = on) (I < 2mA = off)
DO (can also be used as power supply) ..... (Imax Pin3=0.5A / Pin5=2A)	24V
AI and AO .....	24V 4..20mA (0..25mA)
Resolution AI und AO.....	16 Bit
Tolerance (bei +25°C).....	± 0,1% im Bereich 4...20mA
Ambient temperature influence.....	± 0,01%/K

## Diagnose

Open load detection .....	Ja, pro Kontakt
Operating hour counter .....	24 Bit

## Elektrische Anschlüsse

 Earthing / Equipotential bonding via M4 screw and eyelet	
Cable cross-section .....	min. 4,0 mm <sup>2</sup>
CAGE CLAMP® connection technology	
X1-X8 (pluggable) Inputs / Outputs (Ex i)	
Cable cross-section .....	max. 2,5 mm <sup>2</sup>
X9 Power supply (Ex e)	
Cable cross-section .....	max. 2,5 mm <sup>2</sup>
X10 Bus (Ex e)	
Cable cross-section .....	max. 2,5 mm <sup>2</sup>

## Commercial Data

### Zone 1/21

- BEx1-PNIO 8AI 8DIO(AO) 8DIO      Type: 15200104
- BEx1-Modbus 8AI 8DIO(AO) 8DIO      Type: 15200304

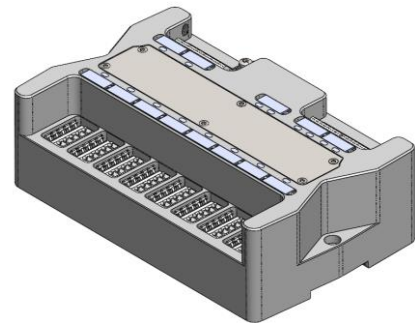

### Zone 1/21

- BEx1-PNIO 8AI 8DIO(AO) 8DIO      Type: 15310104
- BEx1-Modbus 8AI 8DIO(AO) 8DIO      Type: 15310304

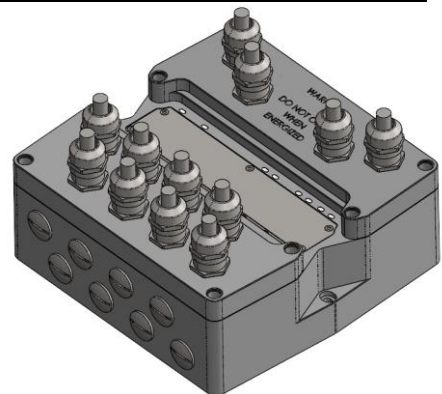

Country of origin .....	DE
Packaging units .....	1
Customs number .....	85176200

## 12 Power Protection X1 bis X8

Sketch

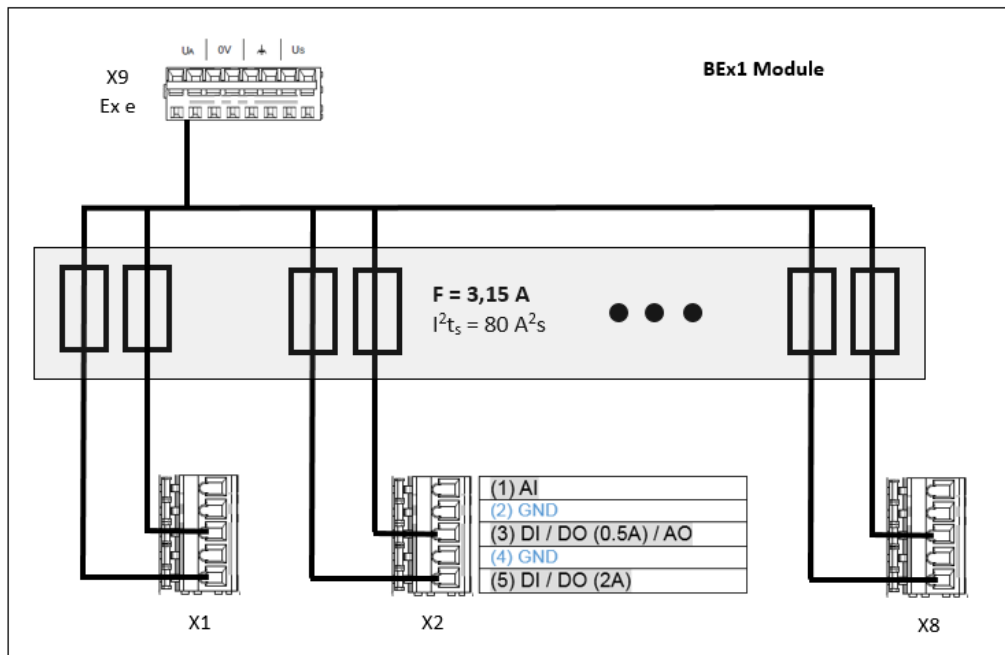

All DO Lines already have an internal fuse.

## 13 Explosion Protection

### 13.1 Specific Conditions of use for BEx1

#### Type 15200\*04 und 15310\*04

- The non-intrinsically-safe terminals of the equipment (terminals X9 and X10) shall be supplied by a source providing SELV output circuit or conforming to IEC 61010 or IEC 60950 (Um=30V DC).

#### Type 15200\*04

- These Remote IO shall be mounted in an enclosure which is fully certified according to the directive 2014/34/EU and the IECEx-Scheme. The installation of the IO modules of the types mentioned above shall be acknowledged by the certification of the enclosure.
- The permitted range of the service temperature after installation inside the additional enclosure is -40 °C to +70 °C.



## 14 Service, Maintenance

The module is maintenance-free.

Observe the intended function.

Follow the guidelines of IEC / EN 60079-17.

According to EN / IEC 60079-17 and EN / IEC 60079-19, the operator of electrical installations in potentially explosive atmospheres is obliged to have these systems checked by a qualified electrician to ensure that they are in a proper condition.

## 15 Repair

The module is complete sealing compound potted and for that basically not repairable. If you have any questions, please contact BEx-Solution GmbH.

## 16 Disposal







Observe the national waste disposal regulations!

## 17 Transport and Storage

Transport and storage are only allowed in original packaging.

## 18 Accessories / Spare parts

On request

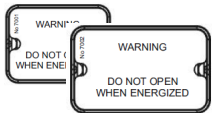
	<p><b>Spring strip with gripping plate for Type *00, *01, *02</b></p> <p>Cable bundling function and unlocking aid 8-pole</p> <p>Use for terminal strip X1-X8</p> <p>Source of supply: Wago</p> <p>Article number: 2091-1108 / 002-000</p>
	<p><b>Snap-on tag color white - UTC-EM (20*8) for IP20 Module</b></p> <p>Use labeling terminal strips</p> <p>Source of supply: Phoenix Contact</p> <p>Article number: 0801477</p>
	<p><b>Coding key carrier; suitable for pitch 3.5 mm for Type *00, *01, *02</b></p> <p>Use for terminal strip X1-X8</p> <p>Source of supply: Wago</p> <p>Article number: 2091-1610</p>
	<p><b>Operating tool; plastic for all Types</b></p> <p>Use for terminal block X9 - X10</p> <p>Source of supply: Wago</p> <p>Article number: 236-332</p>
	<p><b>Ex e cover cap for Type *00, *01, *02</b></p> <p>Use for terminal strip X9</p> <p>Source of supply: BEx-Solution</p> <p>Article number: 7001</p>
	<p><b>Ex e cover cap for Type *00, *01, *02</b></p> <p>Use for terminal strip X10</p> <p>Source of supply: BEx-Solution</p> <p>Article number: 7002</p>
	<p><b>Ex e cover cap set for Type *00, *01, *02</b></p> <p>Use for terminal strip X9 and X10</p> <p>Source of supply: BEx-Solution</p> <p>Article number: 7000 (included 7001 + 7002)</p>

## 19 Troubleshooting

Disruption	Possible causes	Action
The channels do not react	Each channel must be switched on individually	Output Bytes 16 to 19 are set to 0xFF, so all channels are switched on and the outputs are set.
Digital output does not switch anymore	If there is an overload or a short circuit at an output, it will be switched off. The output remains switched off even after removing the error.	To reset the short-circuit memory, the output must be switched off via the PLC.
Error message to unused pins.	No sensors or actuators connected to these pins	The pins can be switched off individually via the Output Bytes 16 to 19.

## EU Declaration of Conformity

### BEx EU/UK - Konformitätserklärung



#### EU/UK- Declaration of conformity / UE/UK – Déclaration de conformité

**BEx-Solution GmbH**  
Lange Str. 99  
76199 Karlsruhe  
Germany

Wir erklären in alleiniger Verantwortung, dass das hier genannte Produkt den aufgeführten Richtlinien (RL) und entsprechenden harmonisierten Normen entspricht.

We declare in sole responsibility that the product complies with the listed directives and harmonized/ designated standards:

Nous déclarons sous notre seule responsabilité que le produit est conforme aux directives et aux normes harmonisées/désignées énumérées :

#### BEx1 Remote IO Modul IP20 Ex e Type 15200\*04

##### Richtlinien / directives / directives

ATEX  
2014/34/EU  
UK SI 2016 No. 1107

EMV / EMC / CEM  
2014/30/EU  
UK SI 2016 No 1091

RoHS  
2011/65/EU  
2015/863/EU  
UK SI 2012 No 3032

REACH  
1907/2006/EG  
UK SI 2021 No 904

##### Normen / Designated standards / Normes

EN IEC 60079-0:2018  
EN IEC 60079-7:2015/A1:2018  
EN 60079-18:2015/A1:2017

EN IEC 61000-6-2:2019-11  
EN IEC 61000-6-4:2020-09

#### Kennzeichnung / Marking / Marquage

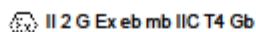



#### EU/UK-Baumusterprüfbescheinigung / EU/UK-Type Examination / Examen de type UE/UK

EPS 19 ATEX 1 219 X  
EPS 22 UKEX 1 045 X

Bureau Veritas Consumer Products Services Germany GmbH  
Notified body No. 2004  
Approved body No. 8507  
Wilhelm-Hennemann-Straße 8, 19061 Schwerin, Germany

#### Qualitätsmanagement System / Quality Management System / Système de gestion de qualité

ISO 9001:2015

Karlsruhe, 2022 / 01 / 14



Ralf Bauermeister / CEO

## BEx EU/UK - Konformitätserklärung



### EU/UK- Declaration of conformity / UE/UK – Déclaration de conformité

**BEx-Solution GmbH**  
Lange Str. 99  
76199 Karlsruhe  
Germany

Wir erklären in alleiniger Verantwortung, dass das hier genannte Produkt den aufgeführten Richtlinien (RL) und entsprechenden harmonisierten Normen entspricht:  
We declare in sole responsibility that the product complies with the listed directives and harmonized/ designated standards:  
Nous déclarons sous notre seule responsabilité que le produit est conforme aux directives et aux normes harmonisées/désignées énumérées :

#### BEx1 Remote IO Modul IP67 Ex e Type 15310\*04

##### Richtlinien / directives / directives

ATEX  
2014/34/EU  
UK SI 2016 No. 1107

##### Normen / Designated standards / Normes

EN IEC 60079-0:2018  
EN IEC 60079-7:2015/A1:2018  
EN 60079-18:2015/A1:2017  
EN 60079-31:2014

EMV / EMC / CEM  
2014/30/EU  
UK SI 2016 No 1091

EN IEC 61000-6-2:2019-11  
EN IEC 61000-6-4:2020-09

RoHS  
2011/65/EU  
2015/863/EU  
UK SI 2012 No 3032

REACH  
1907/2006/EG  
UK SI 2021 No 904

##### Kennzeichnung / Marking / Marquage

 II 2 G Ex eb mb IIC T4 Gb  
II 2 D Ex tb IIIC T110°C Db

**CE**<sup>2004</sup>  
**UK**  
**CA**<sup>8507</sup>

##### EU/UK-Baumusterprüfbescheinigung / EU/UK-Type Examination / Examen de type UE/UK

EPS 19 ATEX 1 219 X  
EPS 22 UKEX 1 045 X

Bureau Veritas Consumer Products Services Germany GmbH  
Notified body No. 2004  
Approved body No. 8507  
Wilhelm-Hennemann-Straße 8, 19081 Schwerin, Germany

##### Qualitätsmanagement System / Quality Management System / Système de gestion de qualité

ISO 9001:2015

Karlsruhe, 2022 / 01 / 14

  
Ralf Bauermeister - CEO

9153\_EU-UK-Konf\_BEx1-IP67-Exe\_2022-01-14

## List of Abbreviations

ATEX	<b>AT</b> mosphères <b>Ex</b> plosibles
AI	Analog Input
AO	Analog Output
BEx1	Product name
CE	Communauté Européenne
DI	Digital Input
DO	Digital Output
Diag	Diagnoses
EMC	Electromagnetic Compatibility
EU	European Union
IEC	International Electrotechnical Commission
IP	International Protection (code)
IO	Input-Output
LED	Light-Emitting Diode
Pin	Terminal
Res	Reserve
UKCA	United Kingdom Conformity Assessed

## Annex 1 Byte allocation of the different modules

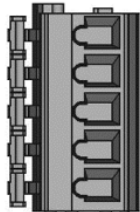

8AI 8DIO(AO) 8DIO	
Type : 15200*04 (IP20)	
Type : 15310*04 (IP67)	
(1)	AI
(2)	GND
(3)	DI / DO (0.5A) / AO
(4)	GND
(5)	DI / DO (2A)

IB = Input byte (Modul → SPS)

OB = Output byte (SPS → Modul)

Type : 15200*04 (IP20)			
Type : 15300*04 (IP67)			
PIN	Function	activated	IO Data
1	AI	OB 16	IB 0..15
2	GND		
3	DI	-	IB17
	DO	OB 17	IB17
	AO	OB 17 OB 23	OB 0..15
4	GND		
5	DI	-	IB 18
	DO	OB 18	IB 18

## Annex 2 - How to activate the functions

- ⇒ All values will be shown as decimal and in brackets in hexadecimal
- ⇒ To activate all functions (AI, AO, DI, DO) for the channels you have to set the output byte 16 to 19 continuously (in each cycle).
- ⇒ The DI give always a back report (unless there are in AO Modul)
- ⇒ Output bytes 17 and 18 switch on/off the DO
- ⇒ AO Modul will be parametric over the output byte 23.
- ⇒ If you don't use a channel, set the corresponding bit to **0** (0x00).

64Output byte – (SPS → Modul)

0	1	2	3	4	5	6	7	8	9	10	11
High	AO	Low									
	X1		AO		AO		AO		AO		AO
			X2		X3		X4		X5		X6

16	17	18	19	20	21	22	23	24	25	26	27
ON/OFF	ON/OFF	ON/OFF	Res	Res	Switch	AO→DO	DO→AO	DO→AI	DO→DI	DO→DI	
X1-X8	X1-X8	X1-X8			mode	X1-X8	X1-X8	X1-X8	X1-X8	X1-X8	
Pin 1	Pin 3	Pin 5			X1-X8	Type *00	Type *01	Type *01	Type *04	Type *04	
					Pin 3	Pin 3	Pin 1	Pin 1	Pin 3	Pin 5	
							Pin 3				

Example for single funktions:

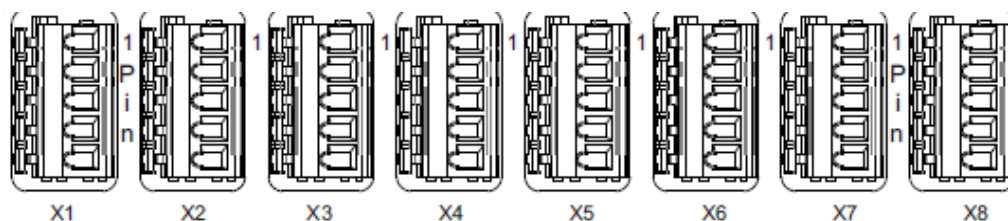

⇒ **Analoge input at Pin 1**

If there are 3 AI Sensors connected on X1, X4 and X8

Clamp	X1	X2	X3	X4	X5	X6	X7	X8
Value	1	2	4	8	16	32	64	128
Connected	yes	-	-	yes	-	-	-	yes

Just add the values: 1 + 8 + 128 = 137 Binär : 10001001 = 137

**Byte 16 = 137 (0x89)**



## ⇒ Digitale output at Pin 3

If there are 4 DO Actuators connected on X3, X5, X6 and X7

Clamp	X1	X2	X3	X4	X5	X6	X7	X8
Value	1	2	4	8	16	32	64	128
Connected	-	-	yes	yes	-	yes	-	yes

Just add the values:  $4 + 8 + 32 + 128 = 172$     Binär :  $10101100 = 172$

**Byte 17 = 172 (0xAC)**

## ⇒ Analog output at Pin 3

If there are 4 AO Actuators connected on X3, X4, X6 and X8

Clamp	X1	X2	X3	X4	X5	X6	X7	X8
Value	1	2	4	8	16	32	64	128
Connected	-	-	yes	yes	-	yes	-	yes

Just add the values:  $4 + 8 + 32 + 128 = 172$     Binär :  $10101100 = 172$

**Byte 17 = 172 (0xAC) – to switch on**

**Byte 23 = 172 (0xAC) – to activate the function DO -> AO**

**Attention:**

**If you use this mode you also have to turn on the equivalent bit in byte 17.**

## ⇒ Digital input at Pin 3 (default)

If there are 5 digital Sensors connected at X1, X2, X3, X4 und X6

Clamp	X1	X2	X3	X4	X5	X6	X7	X8
Value (2 <sup>x</sup> )	1	2	4	8	16	32	64	128
Connected	yes	yes	yes	yes	-	yes	-	-

Just add the values:  $1 + 2 + 4 + 8 + 32 = 47$     Binär :  $00101111 = 47$

**To set the output byte 17 is for that case not necessary.**

## ⇒ Digitale Ausgänge am Pin 5

If there are 3 Do actuators connected at X2, X3 und X4

Clamp	X1	X2	X3	X4	X5	X6	X7	X8
Value (2 <sup>x</sup> )	1	2	4	8	16	32	64	128
Connected	-	yes	yes	yes	-	-	-	-

Just add the values:  $2 + 4 + 8 = 14$       Binär : 00001110 = 14

**Byte 18 = 14 (0x0E)**

## ⇒ Digitale Eingänge am Pin 5 (default)

If there are 6 DI sensors connected at X1, X2, X4, X6, X7 und X8

Clamp	X1	X2	X3	X4	X5	X6	X7		X8
Value (2 <sup>x</sup> )	1	2	4	8	16	32	64		128
Connected	yes	yes	-	yes	-	yes	yes		yes

Just add the values:  $1 + 2 + 8 + 32 + 64 + 128 = 235$       Binär: 11101011 = 235

**To set the output byte 18 is for that case not necessary.**

### Complete Example:

2x AI X2, X7 (24V ; AI ; GND)  
 2x AO X1, X3 (AO ; GND)  
 3x DI X4, X5, X6 (24V ; DI ; GND)  
 3x DO X1, X2, X3 (DO ; GND)

Clamp	X1	X2	X3	X4	X5	X6	X7	X8	Result
Value (2x)	1	2	4	8	16	32	64	128	
Pin 1 (Byte 16)	-	AI	-	-	-	-	AI	-	66
Pin 2 - GND	GND	GND	GND	-	-	-	GND	-	-
Pin 3 (Byte 17)	AO	24V	AO	DI	DI	DI	24V	-	71
Pin 4 - GND	GND	GND	GND	GND	GND	GND	-	-	-
Pin 5 (Byte 18)	DO	DO	DO	24V	24V	24V	-	-	63
D0toAO (Byte 23)	1	-	1	-	-	-	-	-	5

For this example output bytes has to be written into the Bytes 16 to 22.

These values must be transferred each cycle (continuous).

	16	17	18	19	20	21	22	23
	ON/OFF X1-X8 Pin 1	ON/OFF X1-X8 Pin 3	ON/OFF X1-X8 Pin 5	Res	Res			DO->AO X1-X8 Type *01 Pin 1 Type *04 Pin 3
<b>Dez</b>	<b>66</b>	<b>127</b>	<b>63</b>	<b>0</b>	<b>0</b>	<b>0</b>	<b>0</b>	<b>5</b>
<b>Hex</b>	<b>0x42</b>	<b>0x7F</b>	<b>0x3F</b>	<b>0x00</b>	<b>0x00</b>	<b>0x00</b>	<b>0x00</b>	<b>0x05</b>

- ⇒ The digital output DO would be turn on/off through OB18
- ⇒ The value about the analog income AI are from IB0..15.
- ⇒ The value about the analog outcome AO are written about the OB0..15

Free use

Clamp	X1	X2	X3	X4	X5	X6	X7	X8	Result
Value (2 <sup>x</sup> )	1	2	4	8	16	32	64	128	
Pin 1 (Byte 16)									
Pin 2 - GND									
Pin 3 (Byte 17)									
Pin 4 - GND									
Pin 5 (Byte 18)									
DOtoAO (Byte 23)									

Free use

Clamp	X1	X2	X3	X4	X5	X6	X7	X8	Result
Value (2 <sup>x</sup> )	1	2	4	8	16	32	64	128	
Pin 1 (Byte 16)									
Pin 2 - GND									
Pin 3 (Byte 17)									
Pin 4 - GND									
Pin 5 (Byte 18)									
DOtoAO (Byte 23)									

## Annex 3 Connection examples Type \*04

### AI – Analog Input

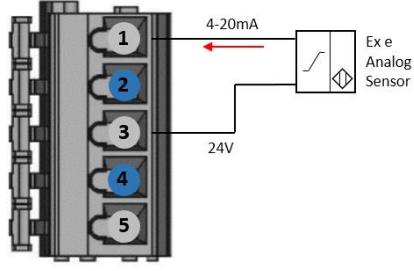
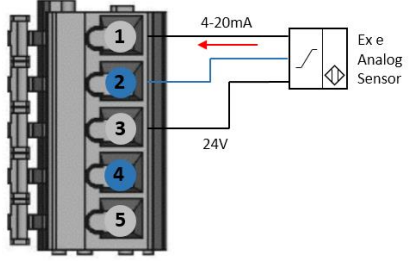
	2 wire connection	3 wire connection
wiring diagram		
App No.	410	
Mode	-	
Open load	yes	
short circuit	yes	

### AI – Analog Input (PT100 or TH)

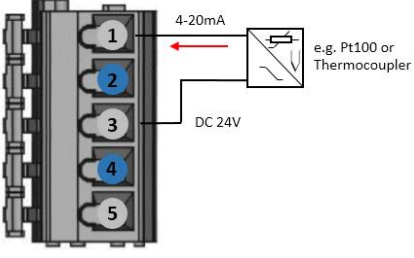
	2 wire connection	3 wire connection
wiring diagram		
App No.	414	
Mode	-	
Open load	yes	
short circuit	yes	
wiring diagram	Temperature head transmitter	

## AO – Analog Output

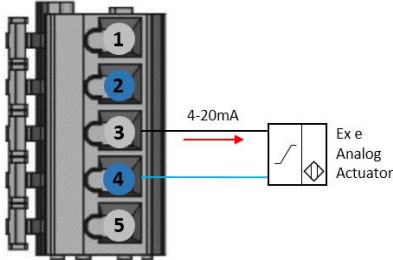
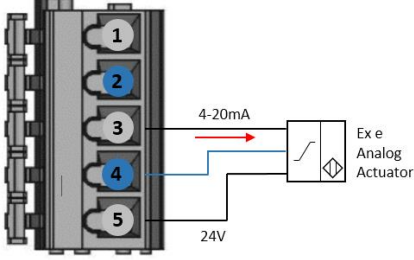
	2 wire connection	3 wire connection
wiring diagram		
App No.	430	
Mode	DO to AO	
Open load	yes	
short circuit	no	

## DI – Digital Input

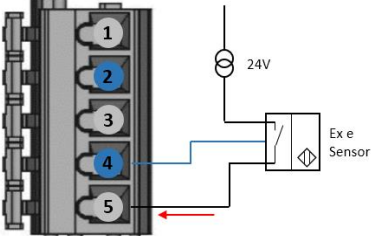
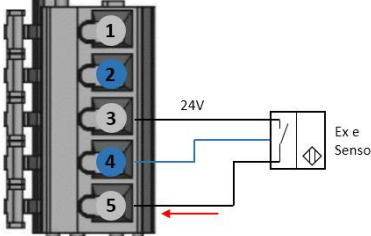
	2 wire connection with external power supply	3 wire connection
wiring diagram		
App No.	450	
Mode	-	
Open load	no	
short circuit	no	

## DI – Digital Input (as mechanical switch)

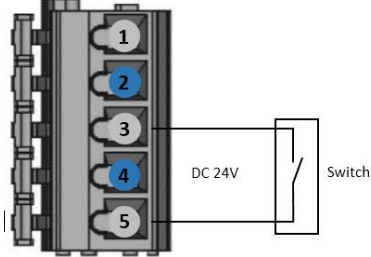
	2 wire connection	3 wire connection
wiring diagram		
App No.	451	
Mode	-	
Open load	no	
short circuit	no	

## DO – Digitaler Ausgang

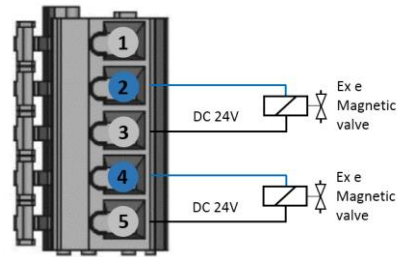
	2 wire connection	3 wire connection
wiring diagram		
App No.	470	
Mode	No one	
Open load	no	
short circuit	yes	







Development, production and sales  
High flexibility for your application  
Customized modifications  
Product individualization

