

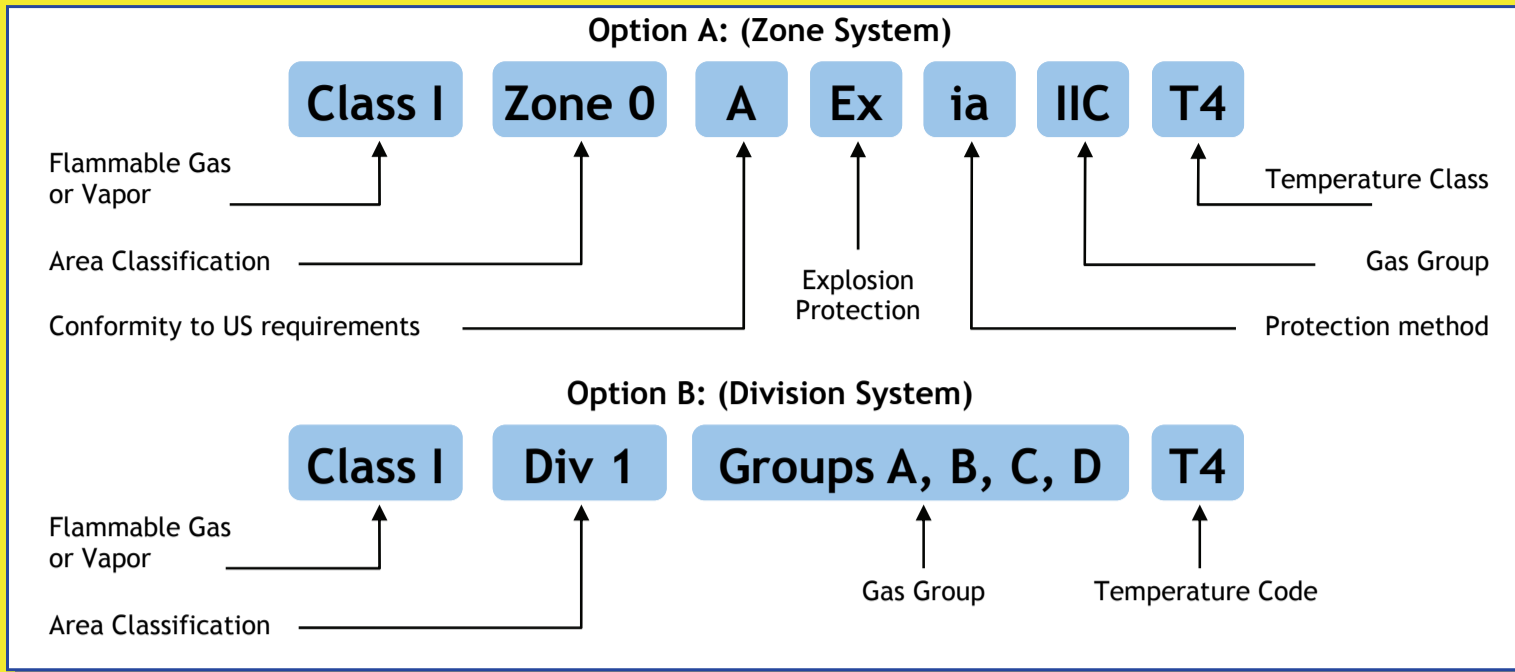

UNDERSTANDING HAZARDOUS LOCATIONS



MARKING FOR NORTH AMERICA ACCORDING NEC / CEC



ELECTRICAL APPARATUS FOR INTRINSICALLY SAFE APPLICATIONS

Field Equipment:
SIMPLE APPARATUS:
 Less than 1.5 V; 0.1 A; 20 μJ; 25 mW. Certification not required (TC, RTD, Pot, Switch, LED ..)
INTRINSICALLY SAFE APPARATUS:
 Require certification. (TX, I/P, Solenoid Valve, Proximity, Field Display ..)
 Safety Parameters to be matched by Associated Apparatus:
 Ui / Vmax (Max. Input Voltage); Ii / Imax (Max. Input Current);
 Ci (Internal Capacitance); Li (Internal Inductance); Pi (Max. Input Power)

Control Room Equipment:
ASSOCIATED APPARATUS:
 Requires certification. (Galvanic Isolators, Zener Barriers, Signal Conditioners)
 Safety Parameters to be matched with Intrinsic Safe Apparatus:
 Uo / Voc (Open Circuit Voltage); Io / Isc (Short Circuit Current);
 Co / Ca (Allowed Capacitance); Lo / La (Allowed Inductance); Po (Max. Power)

NON INTRINSICALLY SAFE APPARATUS:
 All Apparatuses without Approval (PLC, DCS, Computers, Controllers ..)

ELECTRICAL APPARATUS FOR USE IN PRESENCE OF COMBUSTIBLE DUST CATEGORY 1, 2 AND 3

EN 61241-0 Electrical apparatus for use in presence of combustible dust - General Requirements
 EN 61241-1 Electrical apparatus for use in presence of combustible dust - Protection by Enclosures
 EN 61241-11 Electrical apparatus for use in presence of combustible dust - Protection by intrinsic safety

DIVISIONS / ZONES

Area Classification	North America	ATEX
Continuous Hazard	Div. 1 or Zone 0	Div. 1 or Zone 0
Intermittent Hazard	Div. 1 or Zone 1	Div. 1 or Zone 1
Abnormal Conditions Hazard	Div. 2 or Zone 2	Div. 2 or Zone 2

TEMPERATURE CODE / CLASS

Max surface Temperature (°C)	Code / Class	
	North America	ATEX
450	T1	T1
300	T2	T2
280	T2A	-
260	T2B	-
230	T2C	-
215	T2D	-
200	T3	T3
180	T3A	-
165	T3B	-
160	T3C	-
135	T4	T4
120	T4A	-
100	T5	T5
85	T6	T6

ELECTRICAL APPARATUS FOR EXPLOSIVE ATMOSPHERES / CATEGORY 1 AND 2 APPARATUS GAS

Type of protection	Code	IEC /CENELEC standard	US Division Standard	US Zone Standard	Canadian Div. Standard	Canadian Zone Standard
General requirements	-	60079-0	FM3600	UL60079-0	C22.2 No. 0	E60079-0
Intrinsic Safety	Ex ia; ib	60079-11	FM3610/UL913	UL60079-11	C22.2 No. 157	E60079-11
Increased Safety	Ex e	60079-7	-	UL60079-7	-	E60079-7
Flameproof / Expl. Proof	Ex d	60079-1	FM3615/UL1203	UL60079-1	C22.2 No. 30	E60079-1
Pressurization	Ex p	60079-2	NFPA 496	-	CSA TIL 13A	-
Powder filling	Ex q	60079-5	-	UL60079-5	-	E60079-5
Encapsulation	Ex m	60079-18	-	UL60079-18	-	E60079-18
Oil immersion	Ex o	60079-6	-	UL60079-6	-	E60079-6
Type n	Ex n	60079-15	FM3611/UL1604	UL60079-15	C22.2 No. 213	E60079-15
Intrinsically safe systems	Ex ia; ib	60079-25	-	-	-	-
Special requirements	-	60079-26	-	-	-	-

CATEGORY 3 GAS

Type n equipment containing:	Additional code letter
Enclosed break device	C
Non incandive component	C
Hermetically sealed device	C
Sealed device	C
Encapsulated device	C
Energy limited apparatus	L
Restricted breathing enclosure	R
Simplified pressurization	P
Non sparking	A

GAS / DUST GROUPING

Reference Gas / Dust	North America	ATEX
Acetylene	Class I, Group A	Group IIC
Hydrogen	Class I, Group B	Group IIC
Ethylene	Class I, Group C	Group IIB
Propane	Class I, Group D	Group IIA
Methane	Gaseous Mines	Group I
Magnesium	Class II, Group E	-
Coal	Class II, Group F	-
Grain	Class II, Group G	-
Cotton	Class III	-

MARKING ACCORDING ATEX DIRECTIVE 94/9/EC

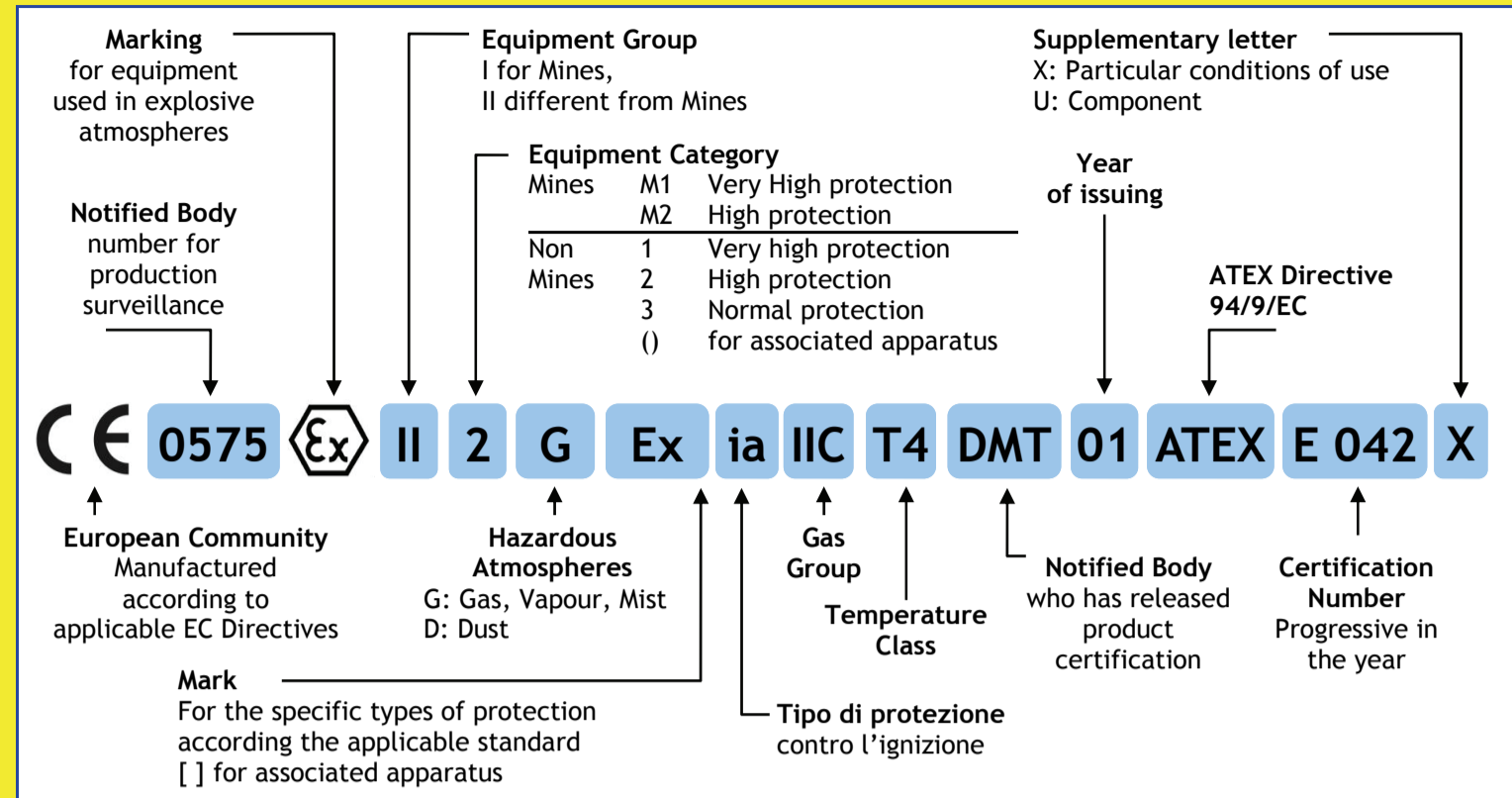

ATEX ZONES AND CATEGORIES

Level of protection		Equipment Category Directive 94/9/EC	Area classification Directive 1999/92/EC
Gas	Dust	ATEX	Typical Zone Suitability
EN 60079-10 0	EN 61241-10 20	High probability of Explosive Atmosphere 1G/1D/M1	Equipment for Zone 0, Zone 20
1	21	Possibility of Explosive Atmosphere 2G/2D/M2	Equipment for Zone 1, Zone 21
2	22	Low probability of Explosive Atmosphere 3G/3D	Equipment for Zone 2, Zone 22

INTRINSICALLY SAFE INSTRUMENTATION FOR HAZARDOUS AREAS



PROTECTION CODE / CLASS

IP Protection Codes			
First numeral Protection against solids		Second numeral Protection against water	
0	No protection	0	No protection
1	Greater than 50 mm	1	Vertical dripping
2	Greater than 12,5 mm	2	Angled dripping (15°)
3	Greater than 2,5 mm	3	Spraying
4	Greater than 1 mm	4	Splashing
5	Dust protected	5	Jetting
6	Dust tight	6	Powerful jetting
		7	Temporary immersion
		8	Continuous immersion

Nema Types		
Type	Application	Protection against
1	Indoor	General purpose
2	Indoor	Dripping water, falling dust
3, 3R, 3S	Outdoor	Rain, snow, windblown dust
4, 4X	Indoor / Outdoor	Hose-Directed water, Corrosion (X)
5	Indoor	Angled dripping water, settling dust
6	Indoor / Outdoor	Temporary Submersion
6P	Indoor / Outdoor	Prolonged Submersion
7	Indoor	Hazardous Location Class I
8	Indoor / Outdoor	Hazardous Location Class I
9	Indoor	Hazardous Location Class II
12, 12K	Indoor	Dripping non-corrosive liquid, Dust
13	Indoor	Water, oil, dust, seepage

DIRECTIVE 94/9/EC - EQUIPMENT AND PROTECTIVE SYSTEMS

Group	Substance	Potentially Explosive Atmosphere	Protection Level	Fault or Protection Mode	Category	Zone
I Mines and surface installation	Methane Grisou and coal dusts	Present	Very High	2 independent faults or 2 protection modes	M1	-
		Probably present	High	1 fault or 1 protection mode	M2	-
II Surface industries and other sites	Gas, vapors, Fogs or Powder	Continuously present, or for long periods	Very High	2 independent faults or 2 protection modes	1	Zone 0 (G) Zone 20 (D)
		Probably present during normal operation.	High	1 fault or 1 protection mode	2	Zone 1 (G) Zone 21 (D)
		Occasionally present for short periods only	Normal	No fault during normal operation	3	Zone 2 (G) Zone 22 (D)

ITALY

G.M. INTERNATIONAL S.R.L
 Via San Fiorano, 70
 20058 Villasanta (MI)
 Tel: +39 039 2325038
 Fax: +39 039 2325107

RUSSIA

OOO G.M. International Rus
 Serpukhovskiy Val 8, Office 10
 115191 Moscow
 Tel: +7 495 950 5779
 Fax: +7 495 952 1006

UNITED STATES OF AMERICA

GM International Safety Inc.
 17453 Village Green Drive
 Houston, TX 77040
 Tel: +1 713 896 0777
 Fax: +1 713 896 0782



info@gmintsrl.com
 www.gmintsrl.com

info@gminternational.ru
 www.gminternational.ru

info@gmisafety.com
 www.gmisafety.com